

Kaweah Project, FERC Project No. 298

AQ 7 – Special-Status Amphibians and Aquatic Reptiles Final Technical Study Report

December 2019



Southern California Edison Company
Regulatory Support Services
1515 Walnut Grove Avenue, Rosemead, CA 91770

Table of Contents

1	Introduction	1
2	Study Objectives	1
3	Extent of Study Area	1
4	Study Approach.....	2
4.1	Foothill Yellow-legged Frog (FYLF).....	2
4.1.1	Historical Information	2
4.1.2	Study Sites	2
4.1.3	Habitat Characterization (Physical and Biotic).....	2
4.1.4	Distribution and Abundance Surveys.....	3
4.1.5	Timing and Length of Breeding Season.....	4
4.1.6	Coordination to Determine Stage and Velocity Effects.....	4
4.1.7	Water Temperature	4
4.2	Western Pond Turtle (WPT)	4
4.2.1	Historical Information	4
4.2.2	Study Sites and Surveys	4
4.2.3	GIS Nesting Habitat Map and Habitat in the Study Area	4
4.2.4	Water Temperature	5
4.2.5	Reporting.....	5
5	Study Results	5
5.1	Foothill Yellow-legged Frog (FYLF).....	5
5.1.1	Historical Information	5
5.1.2	Study Sites	6
5.1.3	Habitat Characterization (Physical and Biotic).....	6
5.1.4	Distribution & Abundance Surveys	6
5.1.5	Timing and Length of Breeding Season.....	7
5.1.6	Coordination to Determine Stage and Velocity Effects.....	7
5.1.7	Water Temperature	7
5.2	Western Pond Turtle.....	7
5.2.1	Historical Information	7
5.2.2	Study Sites and Survey Results.....	8
5.2.3	GIS Nesting Habitat Map and Habitat in the Study Area	8
5.2.4	Water Temperature	8
5.2.5	Reporting.....	8
6	Literature Cited.....	8

List of Tables

Table AQ 7-1. Foothill Yellow-Legged Frog Quantitative Visual Encounter Survey Study Reaches Visited Spring and Summer 2018.....	1
Table AQ 7-2. Study Reach Habitat Type Percentages.....	2
Table AQ 7-3. Physical and Biotic Habitat Observed in Study Reaches during Field Surveys	3
Table AQ 7-4. Amphibian and Aquatic Reptile Species Observed in the Study Reaches.....	6

List of Figures

Figure AQ 7-1. 2018 Survey Reaches for Amphibians, Reptiles, and Other Aquatic Species (Blue Lines=Field Survey Locations). Reach ID Names Correspond to Those Listed in Tables AQ 7-1 and AQ 7-2.....	1
Figure AQ 7-2. Timing of Visual Encounter Surveys in Relation to Stream Flow and Lifecycle Periodicity of FYLF.....	2
Figure AQ 7-3. Potential Habitat for FYLF.....	3
Figure AQ 7-4. Timing of Visual Encounter Surveys in Relation to Stream Temperature and Lifecycle of FYLF	4

List of Maps

Map AQ 7-1. Kaweah Project Survey Reaches Spring, Summer, and Fall 2018	1
Map AQ 7-2. Western Pond Turtle Habitat and 2018 Observations.	3

List of Appendices

Appendix A	Survey Datasets
Appendix B	Habitat Photographs

List of Acronyms

BLM	Bureau of Land Management
°C	degrees Celsius
CNDDDB	California Natural Diversity Database
FERC	Federal Energy Regulatory Commission
FYLF	Foothill Yellow-legged Frog
HSC	Habitat Suitability Criteria
km	kilometer
m	meter
mm	millimeter
MVZ	Museum of Vertebrate Zoology
PCWA	Placer County Water Agency
RSP	Revised Study Plan
SCE	Southern California Edison Company
TSP	Technical Study Plan
TSR	Technical Study Report
USDA	U.S. Department of Agriculture
USFWS	U.S. Fish and Wildlife Service
USGS	U.S. Geological Survey
WPT	Western Pond Turtle

1 INTRODUCTION

This Technical Study Report (TSR) describes the data and findings developed by Southern California Edison Company (SCE) in association with implementation of the AQ 7 – Special-status Amphibians and Aquatic Reptiles Technical Study Plan (AQ 7 – TSP) for the Kaweah Project (Project). The AQ 7 – TSP was included in SCE’s Revised Study Plan (RSP)¹ (SCE 2017a) and was approved by the Federal Energy Regulatory Commission (FERC) on October 24, 2017 as part of its Study Plan Determination for the Project (FERC 2017). Specifically, this report provides a description of the survey methods and results of three site surveys completed in 2018.

2 STUDY OBJECTIVES

The AQ 7 – TSP included six study objectives, as follows:

- Identify and map potential habitat for foothill yellow-legged frog (FYLF) in the study area.
- Document the distribution and abundance of FYLF populations in the study area.
- Document the timing and length of FYLF breeding season, if FYLF are present.
- Characterize the water stage, velocity, and temperature of various flow regimes as it relates to their habitat through coordination with the instream flow and water temperature studies.
- Document the presence of western pond turtle (WPT) during FYLF surveys.
- Document the presence of potential WPT nesting habitat.

3 EXTENT OF STUDY AREA

The study area for FYLF and WPT is the bypass reaches and comparison reaches. The study area for WPT also includes off-channel ponds and wetlands that may be present within the following study areas around Project facilities where maintenance activities occur (Table AQ 7-1).

It should be noted that the majority of lands along the bypass reaches and around select Project facilities are privately owned and outside the FERC Project boundary. For the purposes of the special-status amphibian and reptile surveys described herein, SCE took the following steps to obtain approval to conduct field studies on private property:

- Provided notification to landowner of Project relicensing and requested authorization to enter property to conduct field studies.
- If authorization was obtained, SCE completed field studies as described in this Technical Study Report.
- If authorization was not obtained, SCE limited field studies to only those lands where landowners provided access.

¹ SCE filed a Proposed Study Plan (PSP) on May 24, 2017 (SCE 2017b). Three comments were filed on the PSP, however, they did not result in revisions to any of the study plans. Therefore, SCE filed a Revised Study Plan (RSP) on September 19, 2017, which stated that the PSP, without revision, constituted its RSP. The FERC subsequently issued a Study Plan Determination on October 24, 2017, approving all study plans for the Kaweah Project.

4 STUDY APPROACH

4.1 Foothill Yellow-legged Frog (FYLF)

The following describes the approach used to meet each of the FYLF study objectives (Section 2.0). Also, an additional study component was added to the original study plan to assess biotic conditions important to FYLF, such as 1) periphyton food resources important to larvae, 2) presence of predators/competitors (e.g. non-native crayfish and bullfrogs) known to displace FYLF, and 3) vector lethal pathogens such as chytrid fungus (Kats and Ferrer 2003, Adams et al. 2017).

4.1.1 Historical Information

A review of the available historical FYLF records (Moyle 1973; Hayes et al. 2016; CNDDDB 2018; Lind et al. 2003; museum records) and consultation with agency biologists was completed to identify the historical and/or current distribution of FYLF in the study area.

4.1.2 Study Sites

To determine the distribution and abundance of FYLF within the bypass reaches and comparison reaches, different types of sampling sites were selected. These included sites representative of the river reaches potentially affected by the Project, sites at confluences of tributaries with mainstem river reaches, and comparison sites (including tributaries) where stream flow was not affected by the Project. A stratified sampling approach was used to select representative reaches upstream and downstream of points of hydrologic control, such as a powerhouse or a diversion. Surveyed reaches were sufficiently long to include geomorphic units of multiple riffle-pool sequences. Additional comparison sampling sites were visited in accessible portions of perennial tributaries (i.e., the Marble Fork, Middle Fork, and North Fork Kaweah Rivers) at (or as near as possible) to the confluences with bypass reaches. Comparison sites also included ephemeral tributaries flowing into the Kaweah River (e.g., Salt Creek) where potential breeding habitat and post-metamorphic habitat might exist. In addition, qualitative observations were completed during other studies, particularly mesohabitat mapping (AQ 1 – TSP) to expand the habitat areas searched (SCE 2016, 2017a, b). Table AQ 7-1 lists the surveyed river reaches. Map AQ 7-1 illustrates the distribution of the amphibian and reptile reaches in relation to other biological study sites and Project facilities. Figure AQ 7-1 provides a close-up image of the reaches walked and waded by a pair of observers over the course of the three surveys in 2018 (two surveys in spring and one in late summer).

4.1.3 Habitat Characterization (Physical and Biotic)

Potential breeding and rearing habitat for FYLF was identified and mapped in the bypass reaches based on a review of historical locations where FYLF have been collected, field surveys (see below), and/or observed and inspection of aerial photographs. Potential breeding and rearing habitat was defined as:

- *Breeding Habitat* – Shallow, near-shore areas of low velocity with cobble/boulder substrate in open, sunny areas with little riparian vegetation; often adjacent to low gradient cobble/boulder bars, tributary confluences, side and backwater pools, or pool tail outs with coarse substrates.
- *Rearing Habitat* – Similar to breeding habitats early in the season; but tadpoles may distribute to shallow, warm, low velocity near-shore habitats with smaller substrate (i.e., gravel/sand) as the season progresses.

The river reaches identified as having either historical observations or appropriate channel morphology were visited and infield habitat characterization was completed during distribution and abundance surveys (see Map AQ 7-1). We assessed the presence of suitable low flow velocity environments as well as the algal food availability for tadpoles. We also assessed the presence of native and non-native predators and competitors (e.g. aquatic garter snakes, *Thamnophis couchii*, and American bullfrogs, *Lithobates*

catesbeianus formerly *Rana catesbeiana*, and Signal Crayfish, *Pacifastacus leniusculus*) known to displace FYLF and the potential presence of vector lethal pathogens such as chytrid fungus (Kats and Ferrer 2003, Adams et al. 2017). We also noted the presence of aquatic fauna that occupy low shear stress benthic habitats and thus overlap in terms of suitability with FYLF. These include Western Pearlshell Mussels, *Margaritifera falcata*, (Howard and Cuffey 2003) and Sierra Newts (*Taricha sierrae*), especially their clutches of eggs and larvae. This information was used to infer where FYLF could potentially occur.

A spreadsheet (Appendix A) was prepared listing the locations of potential FYLF habitat following completion of field surveys. We noted the latitude, longitude, and area (number of m²) of habitat patches that might be suitable for various life stages and seasons (i.e., breeding and oviposition habitat in the spring), tadpole habitat in summer, and tributary habitats that could be utilized by juveniles and adults.

4.1.4 Distribution and Abundance Surveys

Surveys at study sites were conducted (Map AQ 7-1; Table AQ 7-1) to determine the presence of FYLF. Surveys followed the Visual Encounter Protocol described in *Measuring and Monitoring Biological Diversity: Standard Methods for Amphibians* (Heyer et al. 1994) and were conducted using the United States Fish and Wildlife Service (USFWS) decontamination guidelines (USFWS 2005 [Appendix A]). Specifically, two surveyors searched streambanks, back channel areas, and potential instream habitats for FYLF progressing in a slow, methodical fashion. To aid in the detection of eggs and tadpoles, surveyors used view tubes in margin areas where needed and possible. During surveys, a minimum of 1,000 meters (m) was surveyed unless accessibility was limited by private property boundaries or physical obstacles such as impassable cascades, bedrock cliffs, etc. For sites located at tributary confluences, a minimum of 1,000 m was surveyed in the mainstem as well as 1,000 m up the tributary where physically possible or as far as the tributary channel was wetted. Data collected during each survey included:

- *Sampling Location and Conditions* – time of survey (start, end, and total search effort), GPS locations (start and end), weather conditions, and water and air temperatures (at start and end of survey) in both the channel margin and main channel; and
- *Observations* – life stage and number of individual of amphibians and reptiles encountered, sex and size if animals were caught and handled, and GPS location.

Three quantitative surveys (i.e., longitudinal transects of approximately 1,000 m per sampling site where feasible) were conducted; two surveys in the spring/early summer for the detection of eggs and early tadpoles (onset of breeding), and one in the late summer/early fall to detect older tadpoles and young-of-the-year. The spring surveys occurred April 23–24 and May 24–28, 2018 when river temperatures had reached a daily average of at least 11 degrees Celsius (°C) in the surveyed locations and when breeding of co-occurring amphibians was taking place (i.e., egg masses or larvae of Sierra Newts, *Taricha sierrae*, and Pacific treefrogs, *Hyla regilla* were found). The late summer survey occurred September 10–14, 2018. Figure AQ 7-2 shows the survey dates in relation to discharge.

In addition, qualitative surveys were conducted once during breeding season and once during the fall to detect young-of-the-year at three additional high-likelihood sites identified from historical records and based on the judgment of the FYLF surveying crew leader after viewing the various riverine habitats during the first ground surveys. The qualitative sampling provided additional FYLF detection coverage in the study area. The locations sampled were on the Marble Fork, the Middle Fork, and North Fork Kaweah Rivers.

A California Native Species Field Survey was submitted to the California Natural Diversity Database (CNDDDB) if FYLF were encountered; however, none were found.

An electronic database (Excel spreadsheet, Appendix A) is provided of herpetofauna and other aquatic taxa of interest (e.g., native freshwater mussels, invasive Asian clams) encountered while searching for FYLF (date, location, and species).

4.1.5 Timing and Length of Breeding Season

FYLF were not found during the spring/early summer surveys (described above): therefore, a third spring survey was not conducted to identify the end of the breeding season.

4.1.6 Coordination to Determine Stage and Velocity Effects

Since FYLF were not found in the Kaweah Watershed, there was no coordination with the instream flow modeling effort (AQ 1 – TSP) or selection of modeling sites to evaluate habitat suitability (local water stage and velocity) for FYLF egg masses and tadpoles, as was proposed in the AQ 7 – TSP. In addition, because FYLF were not found, it was not possible (or applicable) to modify Habitat Suitability Criteria (HSC) information for eggs and tadpoles developed as part of the Middle Fork Project (PCWA 2011) for modeling, as was proposed in the AQ 7 – TSP.

A potential life stage periodicity chart for FYLF was developed, however, that identifies the season of the year (time period) when each life stage would have been present in the study area if they had been present in the watershed.

4.1.7 Water Temperature

The AQ 4 – Water Temperature Modeling study will develop a water temperature model that can be used to identify changes in average, maximum, and minimum daily water temperatures under existing, unimpaired, and alternative flow regimes. Evaluation of existing and unimpaired water temperature regimes, and potential alternative flow regimes (if alternatives are identified) with respect to aquatic habitat will occur in the Draft License Application.

4.2 Western Pond Turtle (WPT)

4.2.1 Historical Information

Known occurrences of WPT within the study area were identified and mapped based on agency consultation and a review of existing information such as CNDDDB (2018), museum records and published studies on turtles in the Kaweah Watershed (Jeffcoach 2014; Ruso et al. 2017), including ecotoxicological studies (Datta et al. 1998; Meyer et al. 2013, 2014, 2016).

4.2.2 Study Sites and Surveys

The FYLF study sites (Section 4.1.2) were surveyed for WPT during the FYLF surveys. In particular, surveyors visually inspected pools and backwaters for WPT at each study site during the FYLF surveys. In addition, potential sightings of WPT during implementation of other aquatic technical studies were recorded, if they occurred. In particular, these included the AQ 1 – Instream Flow Study mesohabitat mapping and field data collection, the AQ 2 – Fish Population study, and the AQ 3 – Benthic Macroinvertebrate study.

4.2.3 GIS Nesting Habitat Map and Habitat in the Study Area

A GIS map of potential WPT nesting habitat locations in the study area was developed. GIS selection criteria included:

- Slope of 15 degrees or less;
- Southeast, south or southwest aspect;
- 150-foot buffer around perennial streams and reservoirs; and
- Below 6,000 feet in elevation.

Field reconnaissance surveys were conducted of potential nesting locations identified near Project facilities.

4.2.4 Water Temperature

The AQ 4 – Water Temperature Modeling study will develop a water temperature model that can be used to identify changes in average, maximum, and minimum daily water temperatures under existing, unimpaired, and alternative flow regimes. Evaluation of existing and unimpaired water temperature regimes, and potential alternative flow regimes (if alternatives are identified) with respect to aquatic habitat will occur in the Draft License Application.

4.2.5 Reporting

No verified WPT were observed during the field studies, therefore; a CNDDDB California Native Species Field Survey Form for WPT was not submitted.

An electronic database (Excel spreadsheet, Appendix A) is available of herpetofauna and other aquatic taxa of interest encountered while searching for FYLF and WPT (date, location, and species).

5 STUDY RESULTS

5.1 Foothill Yellow-legged Frog (FYLF)

5.1.1 Historical Information

There are no recent observations of FYLF in the Kaweah River Watershed. The most recent records date back to 1970, almost 50 years ago (Moyle 1973). At that point in time, FYLF were already uncommon in the region. According to the Conservation Assessment for FYLF (Hayes et al. 2016), Moyle sampled 21 stream crossings of either the mainstem or tributaries of the Kaweah, Tule, or Kern Rivers for frogs, and recorded FYLF at 19% (n = 4) of the crossing points. Three of these sites were in the Kaweah drainage: South Fork Kaweah River, East Fork Kaweah River (ca. 8 miles east-northeast of Lake Kaweah), and North Fork Kaweah River (2 miles W of Sequoia National Park) (Moyle 1973, CNDDDB 2018). No collections or sightings of FYLF exist from Sequoia National Park in the interval from 1980 to present.

The only other relatively recent (i.e., within the last few decades) sightings in the vicinity, were outside the study area, in two unnamed tributaries of the North Fork Kern River in Sequoia National Forest (Lind et al. 2003). The creeks were surveyed multiple times from 1998 to 2002. The last observation of FYLF from one creek was of three adults found by Patrick Kleeman of the U.S. Geological Survey (USGS) on September 12, 1998 (Lind et al. 2003). No frogs were observed at that locality during three subsequent surveys conducted 2002–2003. At least two adult FYLF were observed per survey at the other creek between 1998 and 2002 (Lind et al. 2003).

Prior to 1970, there are records dating back to 1907 in the Kaweah River Watershed according to museum collection searches compiled in the petition filed to protect FYLF under the California Endangered Species Act (Miller 2016):

- Cornell University has a specimen collected from Giant Forest from 1907 (available at: <https://www.cumv.cornell.edu/search-collections.html>).

- The California Academy of Sciences has specimens collected from near Potwisha Camp in Sequoia National Park, dated August 1941 (available at: <http://researcharchive.calacademy.org/research/herpetology/catalog/index.asp>).
- The Harvard Museum of Comparative Zoology has eight frogs collected from Giant Forest in Sequoia National Park (Little Deer Creek, a tributary to the Marble Fork Kaweah River) dated August 1960 (available at: <https://mczbase.mcz.harvard.edu/SpecimenSearch.cfm>).
- The University of California Museum of Vertebrate Zoology has six frogs from the North Fork Kaweah (elevation ~2,000 feet) collected July and August 1935; one frog from Alder Creek Reservoir (elevation ~1,700 feet) in August 1935; one frog from Cottonwood Creek 0.5 mile southeast of Aukland (elevation ~1,300 feet) in June 1938; one frog from 6 miles northeast of Three Rivers on March 29, 1952; and two frogs from 8.5 miles northwest of Woodlake (elevation below 2,000 feet) collected April 1952 (available at: <http://arctos.database.museum/SpecimenSearch.cfm>).

None of these recorded sightings are within the Study Area.

5.1.2 Study Sites

All study sites identified in Section 4.1.2 were sampled (Table AQ 7-1; Map AQ 7-1), including the qualitative reaches in the Middle Fork and Marble Fork, at the safely accessible cobble bars, pool tail outs, and side channels. Details of survey timing, location, and weather conditions are shown in Appendix A, Table A-1. Photographs of the habitat at the study sites is shown in Appendix B.

5.1.3 Habitat Characterization (Physical and Biotic)

Based on longitudinal profile, topography, and geomorphology, the sections of river with the greatest proportion of wide channel cross sections, low gradients, and close proximity to tributaries should offer the best habitat for FYLF (Kupferberg 1996, Rice 2017). In the Kaweah and East Fork Kaweah rivers, the reaches with a relatively high percentage of low gradient mesohabitats (“LGR” in Table AQ 7-2) are: KR US PH1 (46.2%); KR US PH2 (32.1%); KR DS PH2 (24.8%); and EF US CONF KR (22.6%). These reaches had more patches of slow velocity and shallow water that could offer suitable oviposition sites for FYLF (Bondi et al. 2013) than other reaches (Figure AQ 7-3). Habitat photographs are in Appendix B.

Table AQ 7-3 provides a detailed discussion of physical and biotic habitat conditions observed within each of the study reaches during the field surveys. Upstream of the Project (KR US PH3 and EF US K1 DIV), there was little indication of habitat suitable for FYLF. There were only small isolated locations in the river channels with slow velocity habitat and the off-channel tributaries were ephemeral. Similarly, the bypass study reaches in the upstream portion of the Study Area (KR US CONF EF, EF DS K1 DIV) provided limited FYLF habitat. The channels are generally narrow and steep gradient with limited depositional area suitable for breeding and perennial off-channel tributaries are not present. The lower portion of the Kaweah River study area (KR US PH1, KR US PH2, and KR DS PH2), provides pockets of suitable FYLF breeding habitat, including side channels, however, the presence of abundant bullfrogs and other predators such as signal crayfish, likely precludes the possibility of FYLF occupying the habitat.

5.1.4 Distribution & Abundance Surveys

FYLF were not observed in the surveyed reaches. In the reaches where FYLF were expected to be present based on physical habitat, bullfrogs were found (competitors/predators of FYLF) (Table AQ 7-3). Map AQ 7-1 illustrates the locations where aquatic herpetofauna surveyed and Appendix A, Table A-3 provides details of location, number of individuals, body size, etc. Appendix A shows the locations where native invertebrates that share physical habitat requirements with FYLF were found (Appendix A, Table A-4), for example, Western pearl shell mussels which require low shear stress benthic habitats (Howard and Cuffey 2003). The table also shows the presence of non-native predators such as bullfrogs and crayfish that often inhabit locations suitable for FYLF.

It is highly unlikely that FYLF persist in the study area, given the dominance of bullfrogs in the lower elevation reaches, the absence of permanently flowing tributaries in the higher elevation study reaches, and the position of the Watershed downwind of areas in the Central Valley where pesticide use is heavy (Davidson et al. 2004, Sparling et al. 2015). Pacific treefrogs in the area have long shown the negative effects of pesticides (Datta et al. 1998) and FYLF is particularly sensitive to contaminant exposure (Sparling and Fellers 2015, Kerby and Sih 2015). The possibility that a small remnant population may exist somewhere in the greater Kaweah Watershed cannot be completely ruled out because frog populations that have gone undetected for decades are occasionally re-discovered (Backlin et al. 2018).

5.1.5 Timing and Length of Breeding Season

In the absence of the focal species (FYLF), the window of time in which breeding for FYLF might occur in the Kaweah system may be inferred from environmental conditions, breeding of sympatric amphibian taxa, and dates when clutches of eggs were observed in Central Sierran Rivers in 2018. An estimated timing and lifecycle periodicity is shown Figure AQ 7-2.

Water temperature provides a strong cue for FYLF to initiate breeding, however there is variation from watershed to watershed and among years. Observed daily mean water temperatures when oviposition begins has a wide range (9.6 to 16.7°C), with a mean of 12°C (Kupferberg 1996, Wheeler et al. 2018). Water temperatures measured during the spring surveys (first and second survey) were appropriate for FYLF breeding, with the average (\pm SD) = 13.6 \pm 1.9°C across the eight study reaches (Appendix A, Table A-1). The spot measurements and continuous record (Figure AQ 7-4) of water temperatures during late summer (third survey) in the Kaweah River and the East Fork Kaweah River near the confluence with the Kaweah River (daily means in the range of 18–23°C) match the optimal range for FYLF tadpole growth and timely completion of larval development (Catenazzi and Kupferberg 2013, 2018).

5.1.6 Coordination to Determine Stage and Velocity Effects

Given the result that no FYLF were found during the surveys and that FYLF are not known to be extant in the Kaweah River Watershed, local modeling of stage and velocity at FYLF locations was not applicable.

5.1.7 Water Temperature

Evaluation of existing and unimpaired water temperature regimes, and potential alternative flow regimes (if alternatives are identified) with respect to aquatic habitat will occur in the Draft License Application.

5.2 Western Pond Turtle

5.2.1 Historical Information

There are many recent observations of WPT near the study area from two locations in Sequoia National Park that have been the focus of either population monitoring (Jeffcoach 2014), thermal behavior research (Ruso et al. 2017) or ecotoxicological studies (Datta et al. 1998; Meyer et al. 2013, 2014, 2016). One population occupies pools in the permanently flowing reaches of the North Fork Kaweah near the confluence with Yucca Creek approximately 12 kilometers (km) upstream of the study area. The other is in Sycamore Creek, an intermittent tributary of the Middle Fork Kaweah approximately 1 km from the Study Area (see Map AQ 7-1). These sites have long histories of being occupied by WPT as there are collections records from the University of California's Museum of Vertebrate Zoology (MVZ) for both of these sites dating from 1935 (record Nos. MVZ: Herp:19334, 18277, 21910). Turtles in the Kaweah Watershed show evidence of high loads of agricultural pesticides and immunological impairment due to windborne contaminants that drift into the study area from the Central Valley (Datta et al. 1998; Meyer et al. 2013, 2014, 2016).

5.2.2 Study Sites and Survey Results

No WPT were encountered either in the water or on land during the three surveys conducted by the amphibian / reptile surveyors. No incidental observations of WPT occurred during the other aquatic studies. There was one incidental observation of an unidentified turtle on July 25, 2018 in the KR US PH2 reach (i.e., Downstream of Kaweah No.1 Powerhouse and Upstream of Kaweah No. 2 Powerhouse); however, the unidentified turtle was in the vicinity (200 m and 380 m east-southeast) of a pair of ponds where we observed many bullfrogs, known predators of hatchling WPT (Jancowski and Orchard 2013), and there is a high potential that non-native turtles could be present and the observed turtle; therefore, may have been non-native.

Similar to the findings for FYLF, the upstream survey reaches in both the Kaweah and the East Fork Kaweah River where cascades and narrow bedrock canyons were common, provide limited instream habitat for turtles and no large woody debris for basking (Appendix A, Table A-2). Side pools and side channels in the downstream lower gradient reaches (KR US PH1, KR US PH2, KR DS PH2) would provide refuge during high flows for WPT, but again, most suitable habitat was occupied by bullfrogs.

5.2.3 GIS Nesting Habitat Map and Habitat in the Study Area

The GIS analysis indicates that potential nesting habitat exists in a narrow patchy corridor along the Kaweah River and East Fork Kaweah River corridors and along some of the small tributaries / ponds that may maintain permanent water (Map AQ 7-1). During field work we found no evidence of nesting activity in the Project area. During reconnaissance surveys at potential nesting locations identified in the GIS map near project facilities (e.g., powerhouses, diversion pools, and Project roads), we found that a large amount of the GIS identified habitat included substrate (e.g., large cobble/boulders, roadways) and/or dense vegetation that was not suitable for nesting. We did identify potential nesting habitat with suitable substrate on the North side of the river upstream of the Kaweah No. 2 Diversion structure. There is also potential nesting habitat with suitable substrate on the north side of the river near the Kaweah No. 2 Powerhouse. Unnecessary disturbance to these areas should be avoided during Project maintenance.

5.2.4 Water Temperature

Evaluation of existing and unimpaired water temperature regimes, and potential alternative flow regimes (if alternatives are identified) with respect to aquatic habitat will occur in the Draft License Application.

5.2.5 Reporting

No verified WPT were observed during the field surveys.

6 LITERATURE CITED

- Adams, A.J., S.J. Kupferberg, M.Q. Wilber, A.P. Pessier, M. Grefsrud, S. Bobzien, V.T. Vredenburg, and C.J. Briggs. 2017. Extreme drought, host density, sex, and bullfrogs influence fungal pathogen infection in a declining lotic amphibian. *Ecosphere* 8(3)
- Backlin, A.R., J.Q. Richmond, E.A. Gallegos, C.K. Christensen, and R.N. Fisher. 2018. An extirpated lineage of a threatened frog species resurfaces in southern California. *Oryx* 52:718–722.
- Bondi, C.A., S.M. Yarnell, and A.J. Lind. 2013. Transferability of habitat suitability criteria for a stream breeding frog (*Rana boylei*) in the Sierra Nevada, California. *Herpetological Conservation and Biology* 8:88–103.
- Catenazzi, A., and S.J. Kupferberg. 2013. The importance of thermal conditions to recruitment success in stream-breeding frog populations distributed across a productivity gradient. *Biological Conservation* 168:40–48.

- Catenazzi, A., and S.J. Kupferberg. 2018. Consequences of dam-altered thermal regimes for a riverine herbivore's digestive efficiency, growth, and vulnerability to predation. *Freshwater Biology* 63:1037-1048.
- CNDDDB (California Natural Diversity Database). 2018. Rare Find species query for Foothill Yellow-legged Frog (*Rana boylei*). Accessed December 2018.
- Datta, S., L. Hansen, L. McConnell, J. Baker, J. LeNoir, and J.N. Seiber. 1998. Pesticides and PCB contaminants in fish and tadpoles from the Kaweah River Basin, California. *Bulletin of Environmental Contamination and Toxicology* 60:829–836.
- Davidson, C. 2004. Declining downwind: amphibian population declines in California and historical pesticide use. *Ecological Applications* 14:1892–1902
- FERC (Federal Energy Regulatory Commission). 2017. Study Plan Determination for the Kaweah Hydroelectric Project. October 24.
- Hayes, M.P., C.A. Wheeler, A.J. Lind, G.A. Green, and D.C. Macfarlane. 2016. Foothill Yellow-legged Frog conservation assessment in California. Gen. Tech. Rep. PSW-GTR-248. Albany, California: U.S. Department of Agriculture, Forest Service, Pacific Southwest Research Station. 193 p.
- Heyer, W.R., M.A. Donnelly, R.W. McDiarmid, L.C. Hayek and M.S. Foster, Eds. 1994. Measuring and monitoring biological diversity: Standard methods for amphibians. *Biological Diversity Handbook Series*. Washington D.C., Smithsonian Institution Press.
- Howard, J.K., and K.M. Cuffey. 2003. Freshwater mussels in a California North Coast Range river: occurrence, distribution, and controls. *Journal of the North American Benthological Society* 22:63–77.
- Jancowski, K., and S. Orchard. 2013. Stomach contents from invasive American bullfrogs *Rana catesbeiana* (= *Lithobates catesbeianus*) on southern Vancouver Island, British Columbia, Canada. *“NeoBiota”* 16:17–37.
- Jeffcoach, D. 2014. Monitoring anthropogenic contaminants and their effects on wildlife in Sequoia National Park. MS Thesis, California State University, Fresno.
- Kats, L.B., and R.P. Ferrer. 2003. Alien predators and amphibian declines: review of two decades of science and the transition to conservation. *Diversity and distributions* 9:99–110.
- Kerby, J.L., and A. Sih. 2015. Effects of carbaryl on species interactions of the Foothill Yellow-legged Frog (*Rana boylei*) and the Pacific treefrog (*Pseudacris regilla*). *Hydrobiologia* 746:255–269.
- Kupferberg, S.J. 1996. Hydrologic and geomorphic factors affecting conservation of a river-breeding frog (*Rana boylei*). *Ecological Applications* 6:1332–1344.
- Lind, A.J., L. Conway, H.E Sanders, P. Strand, and T. Tharalson. 2003. Distribution, relative abundance, and habitat of foothill yellow-legged frogs (*Rana boylei*) on national forests in the Southern Sierra Nevada Mountains of California. Vallejo, California: U.S. Department of Agriculture, Forest Service, Pacific Southwest Region. 30 p.
- Meyer, E., D. Sparling, and S. Blumenshine. 2013. Regional inhibition of cholinesterase in free-ranging western pond turtles (*Emys marmorata*) occupying California mountain streams. *Environmental toxicology and chemistry*. 32:692–698.
- Meyer, E., C.A. Eagles-Smith, D. Sparling, and S. Blumenshine. 2014. Mercury exposure associated with altered plasma thyroid hormones in the declining Western Pond Turtle (*Emys marmorata*) from California mountain streams. *Environmental Science and Technology* 48:2989–2996.

- Meyer, E., E.A. Eskew, L. Chibwe, J. Schrlau, S.L.M. Simonich, and B.D. Todd. 2016. Organic contaminants in western pond turtles in remote habitat in California. *Chemosphere* 154:326–334.
- Miller, J. 2016. Petition to list the Foothill Yellow-Legged Frog (*Rana boylei*) as threatened under the California Endangered Species Act before the Fish and Game Commission. Available at: https://www.biologicaldiversity.org/species/amphibians/foothill_yellow-legged_frog/pdfs/FYLF_state_petition_12-14-16.pdf. Accessed Jan. 29, 2019.
- Moyle, P.B. 1973. Effects of introduced Bullfrogs, *Rana catesbeiana*, on the native frogs of the San Joaquin Valley, California. *Copeia* 1973:18–22.
- PCWA (Placer County Water Agency). 2011. Application for New License. Middle Fork American River Project (FERC Project No. 2079). AQ 1 – Instream Flow Technical Study Report (2010). Exhibit E, Volume 3, Supporting Document B. February 2011.
- Rice, S.P. 2017. Tributary connectivity, confluence aggradation, and network biodiversity. *Geomorphology* 277:6–16.
- Ruso, G.E., E. Meyer, and A. J. Das. 2017. Seasonal and diel environmental conditions predict Western Pond Turtle (*Emys marmorata*) behavior at a perennial and an ephemeral stream in Sequoia National Park, California. *Chelonian Conservation and Biology* 16:20–28.
- SCE (Southern California Edison Company). 2016. Kaweah Project Pre-Application Document. Filed with FERC on December 6.
- SCE. 2017a. Kaweah Project, Revised Study Plan. Filed with FERC on September 19.
- SCE. 2017b. Kaweah Project, Proposed Study Plan. Filed with FERC on May 24.
- Sparling, D.W., J. Bickham, D. Cowman, G.M. Fellers, T. Lacher, C.W. Matson, and L. McConnell. 2015. In-situ effects of pesticides on amphibians in the Sierra Nevada. *Ecotoxicology* 24:262–278.
- USFWS (U.S. Fish and Wildlife Service). 2005. *Revised Guidance on Site Assessments and Field Surveys for the California Red-legged Frog, August 2005*.
- Wheeler, C.A., A.J. Lind, H.H. Welsh Jr, and A.K. Cummings. 2018. Factors that Influence the Timing of Calling and Oviposition of a Lotic Frog in Northwestern California. *Journal of Herpetology* 52:289–298.

TABLES

This Page Intentionally Left Blank

Table AQ 7-1. Foothill Yellow-Legged Frog Quantitative Visual Encounter Survey Study Reaches Visited Spring and Summer 2018

Study Reach	Length, km, of Survey ¹	Bypass Reaches	Comparison Reaches ²	Stream / River Type
Kaweah River				
Kaweah River Upstream of Kaweah No. 3 Powerhouse (KR US PH3)	1.0 (0.5)		●	Mainstem (Ephemeral Tributary)
Kaweah River Downstream of Kaweah No. 3 Powerhouse and Upstream of the East Fork Kaweah River Confluence (KR US CONF EF)	1.0	●		Mainstem (Perennial Tributary Confluence)
Kaweah River Downstream of East Fork Kaweah Confluence and Upstream of Kaweah No. 1 Powerhouse (KR US PH1)	2.77 (0.5)	●		Mainstem (Ephemeral Tributary)
Kaweah River Downstream of Kaweah No.1 Powerhouse and Upstream of Kaweah No. 2 Powerhouse (KR US PH2)	1.35 (0.5)	●		Mainstem (Ephemeral Tributary, Salt Creek)
Kaweah River Downstream of Kaweah No. 2 Powerhouse (KR DS PH2)	1.18 (0.37)		●	Mainstem (Perennial Tributary, North Fork Kaweah River)
East Fork Kaweah River				
East Fork Kaweah River Upstream of Kaweah No. 1 Diversion (EF US K1 DIV)	0.45 (0.2)		●	Mainstem (Ephemeral Tributary)
East Fork Kaweah River Downstream of the Kaweah No. 1 Diversion (EF DS K1 DIV)	0.19 (0.67)	●		Mainstem (Ephemeral Tributary)
East Fork Kaweah River Upstream of Confluence with Kaweah River (EF US CONF KR)	0.89 (0.13)	●		Mainstem (Ephemeral Tributaries)

Notes:

¹Mainstem (Tributary)²Upstream or downstream of the Project

Table AQ 7-2. Study Reach Habitat Type Percentages.

Study Reach	HGR*	LGR*	Run*	Pool*	Cascade*	Reach Length (ft)
Kaweah River						
Kaweah River Upstream of Kaweah No. 3 Powerhouse (KR US PH3)	30.0%	2.0%	4.0%	64.0%	0.0%	5280
Kaweah River Downstream of Kaweah No. 3 Powerhouse and Upstream of the East Fork Kaweah River Confluence (KR US CONF EF)	19.6%	5.1%	27.0%	40.7%	7.7%	2789
Kaweah River Downstream of East Fork Kaweah Confluence and Upstream of Kaweah No. 1 Powerhouse (KR US PH1)	13.3%	46.2%	14.8%	23.0%	2.7%	9959
Kaweah River Downstream of Kaweah No. 1 Powerhouse and Upstream of Kaweah No. 2 Powerhouse (KR US PH2)	38.1%	32.1%	3.6%	25.6%	0.6%	8471
Kaweah River Downstream of Kaweah No. 2 Powerhouse (KR DS PH2)	17.0%	24.8%	28.8%	27.6%	1.8%	8146
East Fork Kaweah River						
East Fork Kaweah River Upstream of the Kaweah No. 1 Diversion (EF US K1 DIV)	33.0%	7.0%	0.0%	54.0%	6.0%	5280
East Fork Kaweah River Downstream of the Kaweah No. 1 Diversion (EF DS K1 DIV)	39.2%	0.0%	15.6%	30.9%	14.3%	22427
East Fork Kaweah River Upstream of Confluence with Kaweah River (EF US CONF KR)	8.6%	22.6%	6.3%	47.5%	15.1%	2477

Notes: HGR = High gradient riffle, LGR = Low gradient riffle, Run = habitat with greater depth than riffles (but with little residual depth a very low flow) and much less surface turbulence than riffles, Pools = habitats with the greatest depth, including residual depth at very low flow, and Cascades = Very steep turbulent habitats.

Table AQ 7-3. Physical and Biotic Habitat Observed in Study Reaches during Field Surveys*Upstream of Kaweah No. 3 Powerhouse (KR US PH3) (Comparison Reach)*

A search was conducted of a reach of the mainstem Kaweah upstream and downstream of the confluence with a tributary that flows through a drainage near the Ash Mountain Visitor Center. The tributary is very shaded except at the confluence with the Kaweah and suitable only for post-metamorphic life stages of FYLF. The mainstem reach is dominated by high gradient bedrock / boulder cascades and rapids (Table AQ 7-2). Accordingly, five small (4–8 m²) patches of habitat at pool tail outs were identified that potentially could be suitable for FYLF breeding. Sparse patches of low velocity habitat also occurred in side pools and side channels (Appendix A, Table A-2).

During the first survey, Sierra Newts (*Taricha sierrae*) were observed breeding in step pools of the heavily shaded tributary and Pacific treefrogs (*Hyla regilla*) breeding in scour holes in bedrock along the margins of the mainstem channel (Appendix B, Photo B-1). During the second survey, hundreds of treefrog tadpoles were observed in elliptically shaped pools (3 m long x 5 m wide x 2 m deep) with water temperatures at 20°C. This was considerably warmer than the mainstem which was between 13 and 14°C. By the third survey these isolated pools were dry, as was the tributary creek. Because only small and isolated patches of shallow slow velocity habitat were observed in this reach at pool tailouts and because the tributary and off channel water bodies were ephemeral, there is little indication that the surveyed reach could support a population of FYLF.

Downstream of Kaweah No. 3 Powerhouse and Upstream of the East Fork Kaweah River Confluence (KR US CONF EF)

The only amphibians found in this reach were Pacific treefrogs. Adults were observed at a bedrock outcrop where a leak in the flume created a small rivulet (Appendix B, Photo B-2). The mainstem channel, dominated by bedrock and boulders, offered very few patches of suitable slow velocity habitats along the margins where FYLF could potentially breed, and none of these patches were in close proximity to a winter refuge habitat of a small creek or seep. Side channels where water was flowing at the high snowmelt discharge had suitable FYLF breeding habitat, but became completely dry before FYLF tadpoles would be able to metamorphose. Furthermore, this reach has been modified by buildings and homes along the channel on the less steep bank (river right) which further compromises the upland habitat needed by FYLF.

Kaweah River Downstream of East Fork Kaweah Confluence and Upstream of Kaweah No. 1 Powerhouse

In this reach when spring snowmelt discharge was high, searches focused in and around a tributary (an unnamed creek) that had step pool morphology that would be appropriate for adult and juvenile FYLF to overwinter (Appendix B, Photo B-3). If FYLF were present in the system, they would have been detected migrating downstream to breeding sites on the mainstem Kaweah River. Upstream and downstream of the tributary confluence, there are side channels where water was flowing at high snowmelt discharge during Surveys 1 and 2 and which offered small pockets of suitable FYLF breeding habitat. However, the side channels become completely dry before FYLF tadpoles would be able to metamorphose. In the tributary, juvenile bullfrogs, adult treefrogs and their eggs, and adult newts and their eggs in the spring were observed. The tributary was completely dry in September. For the main channel, the deeper side pools that remained wet through the second and third survey were inhabited by bullfrogs.

Downstream of Kaweah No. 1 Powerhouse and Upstream of Kaweah No. 2 Powerhouse (KR US PH2)

During the first survey, when spring snowmelt discharge made the main channel inaccessible in this reach, searches focused on Salt Creek. Based on the presence of breeding newts and treefrogs and the step pool morphology, it would be appropriate habitat for adult and juvenile FYLF (Appendix B, Photo B-4). The creek was dry near the confluence with the Kaweah River by the third survey and thus could not support breeding by FYLF. The side channel of the Kaweah River upstream of the confluence with Salt Creek was used by bullfrogs for breeding as indicated by numerous young-of-the-year bullfrog tadpoles (i.e., body size 20–25 millimeter [mm]) present during the third survey.

Downstream of Kaweah No. 2 Powerhouse and North Fork Kaweah (KR DS PH2) (Comparison Reach)

In this reach of the Kaweah River, the suitably slow and shallow conditions for FYLF occurred in side channels, midchannel islands that were vegetated with willows and alders, and cobble bars along the banks of the main channel (Appendix B, Photo B-5). These mesohabitats were occupied by all life stages of bullfrogs (adults, juveniles, and two size classes of tadpoles). Periphyton food resources for tadpoles consisted of diatom covered rocks early in the spring, and in late summer filamentous green algae, including *Cladophora* with epiphytic diatoms, which offer high-quality food to tadpoles.

Similarly, in the North Fork Kaweah River suitable habitat for FYLF was occupied by bullfrogs. Native herpetofauna there included treefrog adults and recently metamorphosed juveniles, and garter snakes. Non-native Signal Crayfish and Asian Clams were also observed.

Both of these reaches have high levels of human recreational use and development with homes and roads along the river which limit the upland and off-river habitats that FYLF might utilize during periods of flood disturbance in the main channel.

East Fork Kaweah Upstream of Kaweah No. 1 Diversion (EF US K1Div) (Comparison Reach)

This reach offered very little suitable habitat for FYLF breeding because it is dominated by cascades and the side tributaries are ephemeral (Appendix A, Table A-2). A low gradient pool had scattered boulders and cobbles over sand and was the one location that might be suitable as indicated by the presence of newt larvae under the rocks (Appendix B, Photo B-6).

East Fork Kaweah Downstream of the Kaweah No. 1 Diversion (EF DS K1Div)

This reach, dominated by bedrock cascades, was inaccessible at high snowmelt flows. At low flow during the third survey, pockets of cobble and boulder habitat were identified that might be suitable for FYLF as indicated by the presence of aquatic garter snakes and newt larvae. Tributaries where eggs and larvae of treefrogs and newts were found in spring were completely dry by September. . In terms of periphyton food resources for tadpoles, this reach was dominated by relatively low food quality mucilaginous filamentous green algae such as *Mougeotia* and *Spirogyra*.

East Fork Kaweah Upstream of Confluence with Kaweah River (EF US CONF KR)

Habitats suitable for FYLF in this reach included side pools where treefrogs were observed and main channel pools where several aquatic garter snakes and large Western Pearlshell Mussels were observed (*Margaritifera falcata*, shell length 50–105 mm) near channel margins

(Appendix B, Photo B-8). The ephemeral tributaries where treefrog tadpoles were found approaching metamorphosis (Appendix A, Table A-3) during the second survey would be suitable for post-metamorphic life stages of FYLF. The hydroperiod of the tributaries is too short for FYLF larval development which takes 2 to 3 months (Catenazzi and Kupferberg 2013).

Table AQ 7-4. Amphibian and Aquatic Reptile Species Observed in the Study Reaches

Study Reach	Species, stream type ¹	Life stage (survey # ²)
Kaweah River		
KR US PH3	Pacific treefrog, <i>Hyla regilla</i> , mainstem Sierra newt, <i>Taricha sierrae</i> , tributaries and mainstem	Eggs (1), tadpoles (2) Adults (1, 2), gravid females (1) Eggs (1, 2) Larvae (2, 3)
KR US CONF EF	Pacific treefrog, <i>Hyla regilla</i> , mainstem	Adults (2)
KR US PH1	Pacific treefrog, <i>Hyla regilla</i> , mainstem American bullfrogs, <i>Lithobates catesbeianus</i> , tributaries and mainstem	Adults, tadpoles (1) Adults, juveniles, tadpoles
KR US PH2	Pacific treefrog, <i>Hyla regilla</i> , tributaries American bullfrogs, <i>Lithobates catesbeianus</i> , tributaries, mainstem Sierra newt, <i>Taricha sierrae</i> , tributaries	Eggs (1), tadpoles (2) Adults (1), juveniles, tadpoles (3) Adults (1), eggs (1), larvae (2)
KR DS PH2	Garter snake, <i>Thamnophis couchii</i> , mainstem	Adults, juveniles, tadpoles (3)
East Fork Kaweah River		
EF US K1 DIV	Sierra newt, <i>Taricha sierrae</i> , tributary, mainstem	Adults (1), eggs (1), larvae (3)
EF DS K1 DIV	Pacific treefrog, <i>Hyla regilla</i> , tributary, mainstem Sierra newt, <i>Taricha sierrae</i> , tributary, mainstem Garter snake, <i>Thamnophis couchii</i> , mainstem	Adults (3), tadpoles (2) Adults (2), eggs (1), larvae (2) Adults (3)
EF US CONF KR	Pacific treefrog, <i>Hyla regilla</i> , tributary, mainstem Garter snake, <i>Thamnophis couchii</i> , mainstem	Adults (2, 3), tadpoles (2) Adults (2)
Additional Sites within Kaweah Drainage		
Marble Fork and Middle Fork Kaweah River	Pacific treefrog, <i>Hyla regilla</i>	Adults (1)
North Fork Kaweah River	Pacific treefrog, <i>Hyla regilla</i> American bullfrogs, <i>Lithobates catesbeianus</i> Garter snake, <i>Thamnophis couchii</i>	Adults, metamorphs (3) Tadpoles (3) Adult (3)

Notes: Numbers in parentheses indicate survey round. For locations see Map AQ 7-1; for numbers of individuals, body sizes, habitat notes, etc. see Appendix A, Table A-3.

¹Common Names: Pacific Treefrog (*Hyla regilla*), American Bullfrog (*Lithobates catesbeianus*), Sierra Newt (*Taricha sierrae*), Sierra Garter Snake (*Thamnophis couchii*).

²Survey dates: 1 = April 23–24 2018
2 = May 24–28 2018
3 = Sept 10–14 2018

FIGURES

This Page Intentionally Left Blank

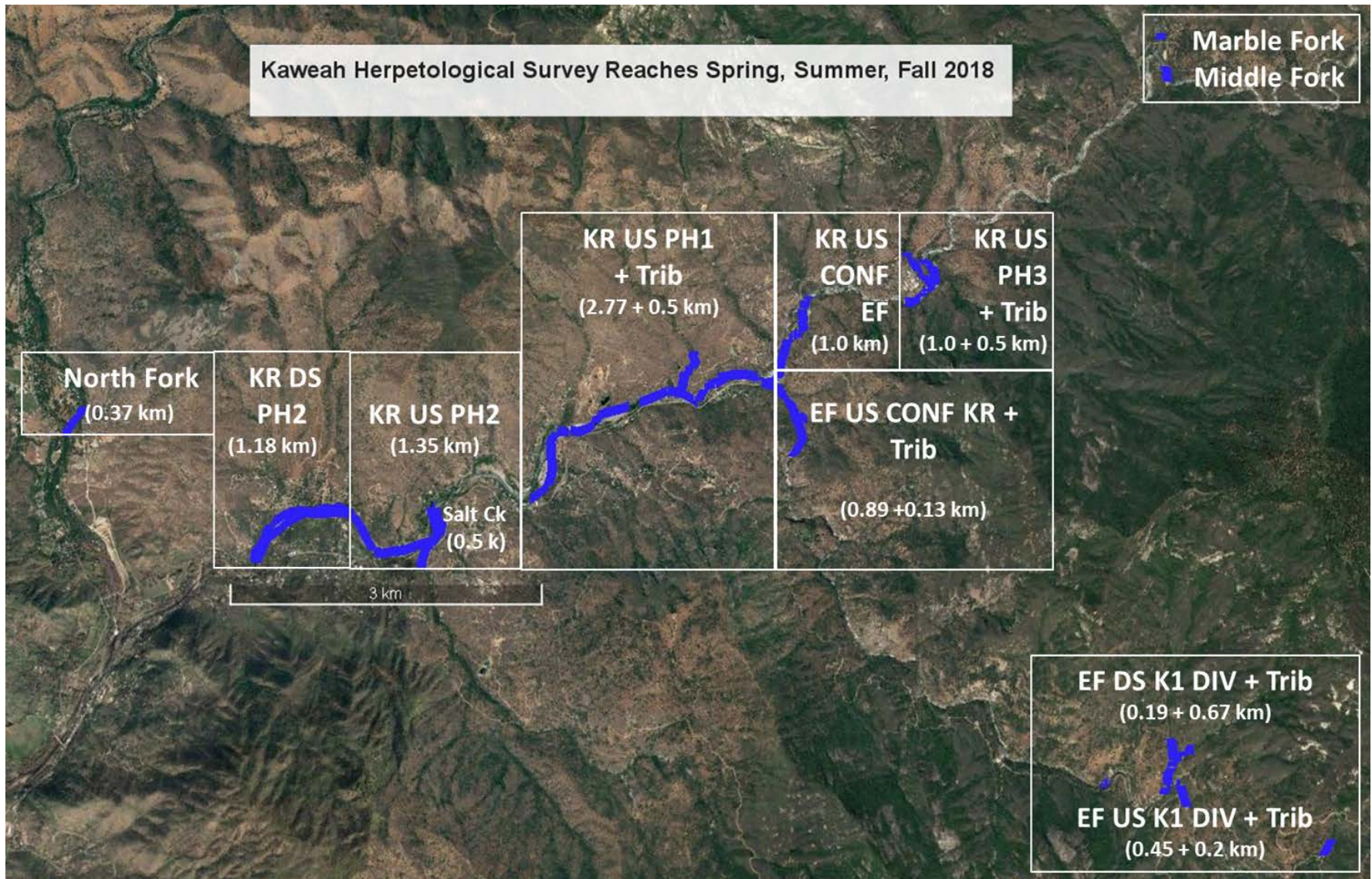

Figure AQ 7-1. 2018 Survey Reaches for Amphibians, Reptiles, and Other Aquatic Species (Blue Lines=Field Survey Locations). Reach ID Names Correspond to Those Listed in Tables AQ 7-1 and AQ 7-2

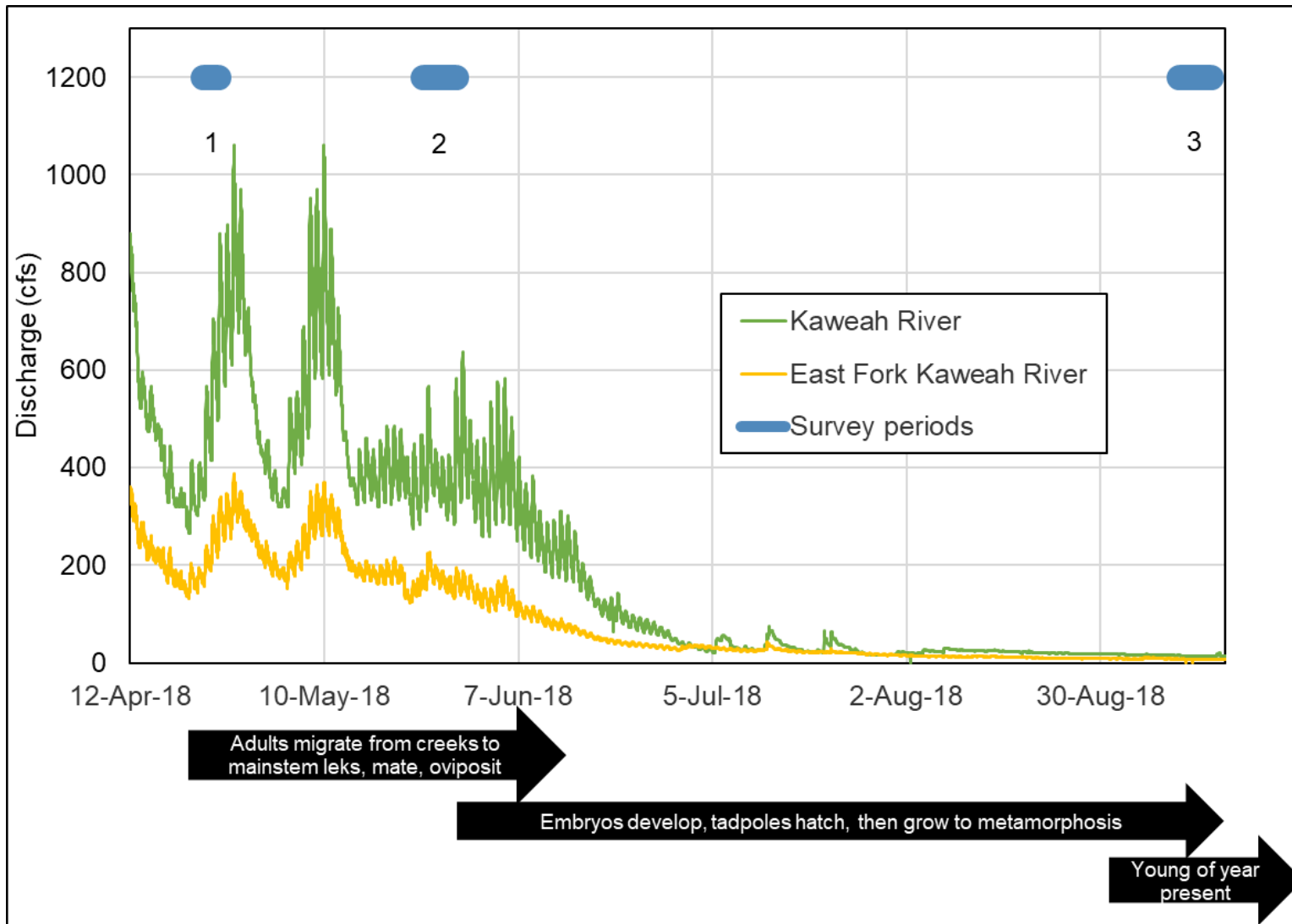
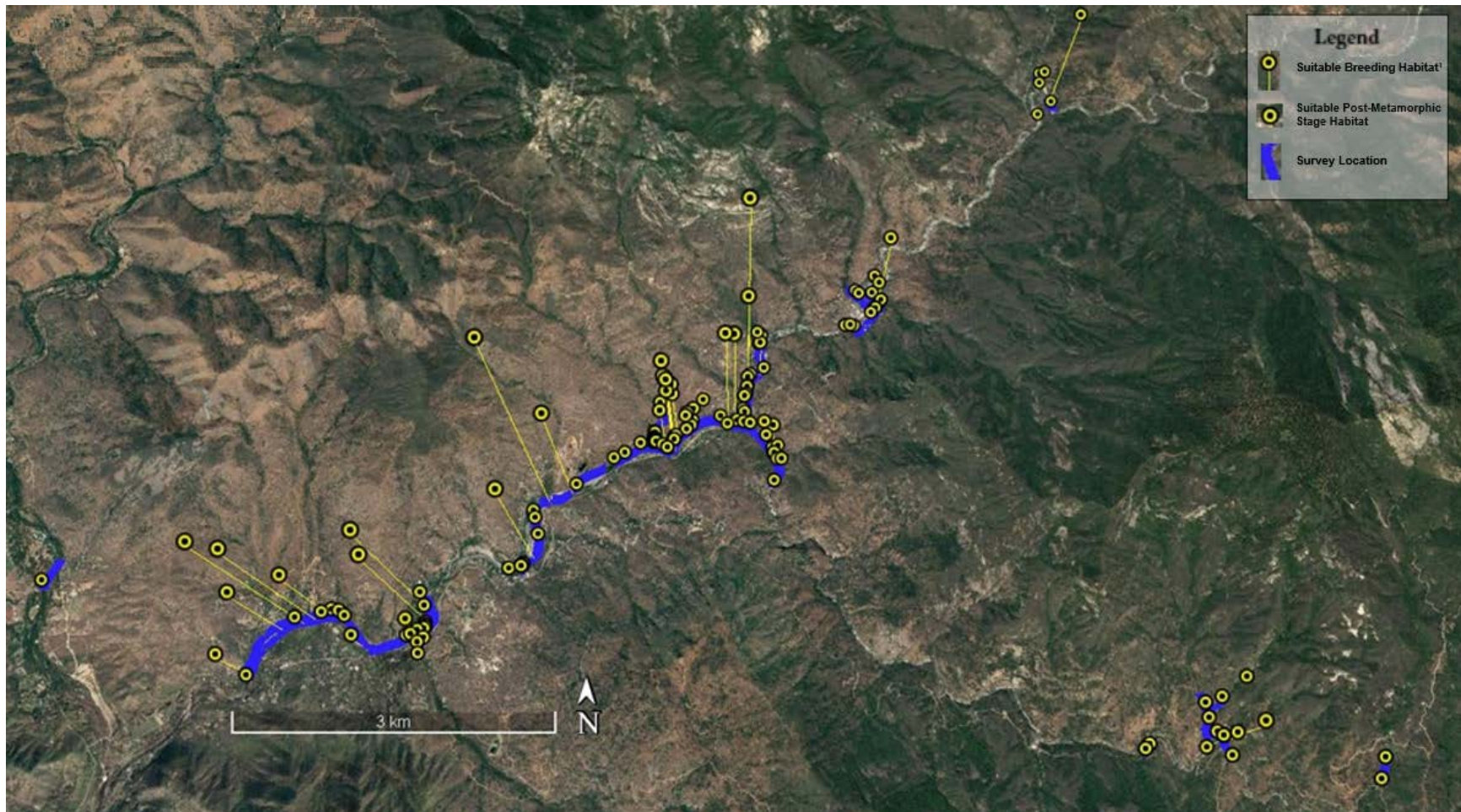

Figure AQ 7-2. Timing of Visual Encounter Surveys in Relation to Stream Flow and Lifecycle Periodicity of FYLF



¹Height of the points is proportionate to the area (m²) of oviposition and tadpole habitat at that location.

Figure AQ 7-3. Potential Habitat for FYLF

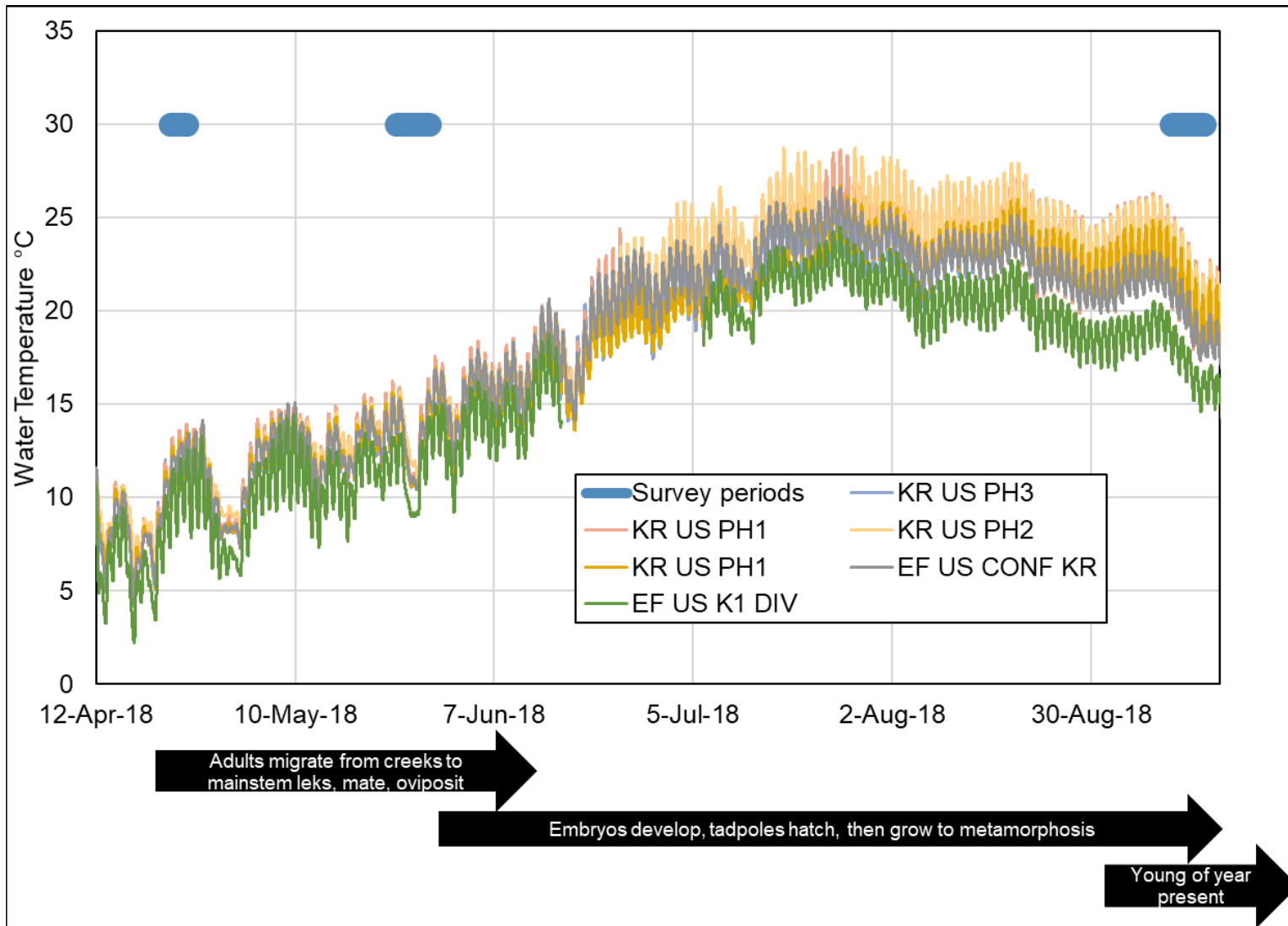
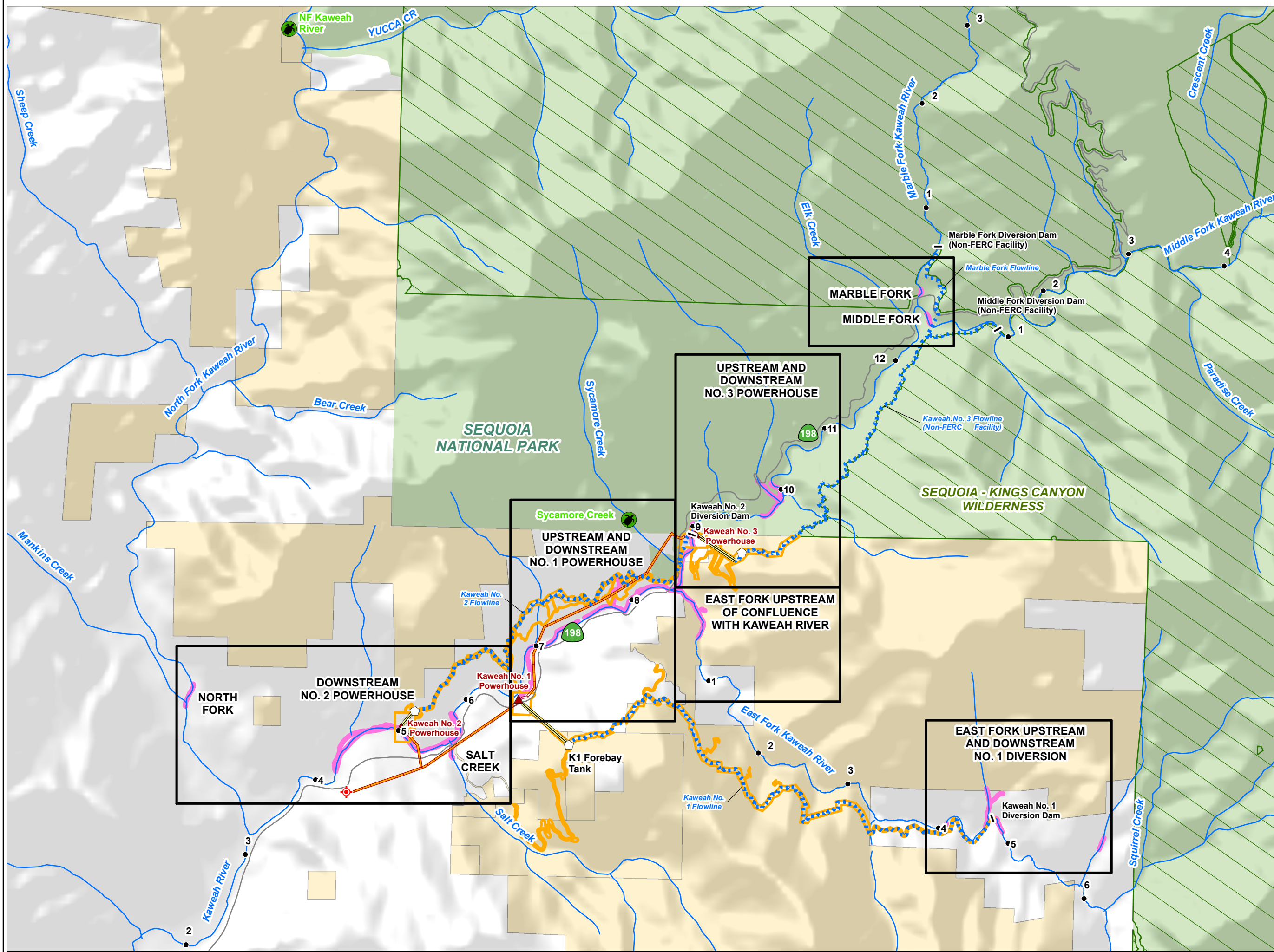



Figure AQ 7-4. Timing of Visual Encounter Surveys in Relation to Stream Temperature and Lifecycle of FYLF

MAPS

This Page Intentionally Left Blank



- SCE Facilities**
- Powerhouse
 - Diversion
 - Forebay
 - Flowline
 - Penstock
 - Transmission Line
 - FERC Boundary
- Other Features**
- Highway/Road
 - Watercourse
 - Water Body
 - River Mile
- Land Jurisdiction***
- Bureau of Land Management
 - National Park Service
 - Private (Blank)
- *SOURCE: BLM 2016
- Land Management**
- National Wilderness Area
- Western Pond Turtle Data**
- FYLF (No Known Locations)
 - Western Pond Turtle**
- ** SOURCE: Ruso et al. 2017
- AQ7 Survey**
- Herpetological Survey Reaches



**SOUTHERN CALIFORNIA
EDISON**
An EDISON INTERNATIONAL® Company

FERC Project No. 298

Map AQ 7-1
Kaweah Project
Herpetological Survey Reaches
Spring, Summer, Fall 2018



Date: 4/22/2019

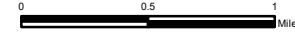

0 0.5 1 Miles

Projection: UTM Zone 11
Datum: NAD 83

Southern California Edison (SCE) has no reason to believe that there are any inaccuracies or defects with information incorporated in this work and make no representations of any kind, including, but not limited to, the warranties of merchantability or fitness for a particular use, nor are any such warranties to be implied, with respect to the information or data, furnished herein. No part of this map may be reproduced or transmitted in any form or by any means, electronic or mechanical, including photocopying and recording system, except as expressly permitted in writing by SCE.

Copyright 2019 by Southern California Edison Company

This Page Intentionally Left Blank

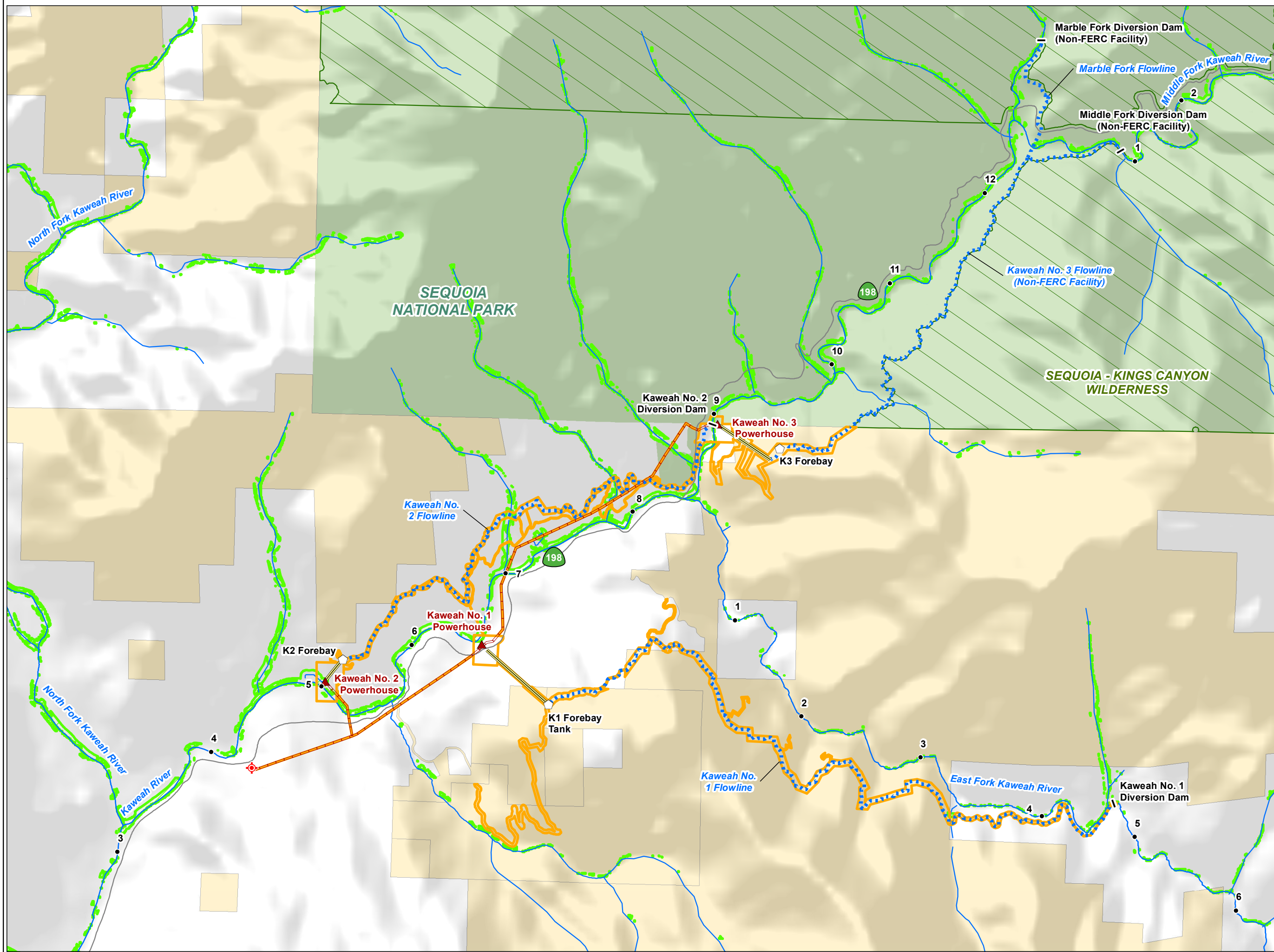

- SCE Facilities**
- ▲ Powerhouse
 - Diversion
 - ◻ Forebay
 - ... Flowline
 - Penstock
 - Transmission Line
 - FERC Boundary
- Other Features**
- Highway/Road
 - Watercourse
 - Water Body
 - River Mile
- Land Jurisdiction***
- Bureau of Land Management
 - National Park Service
 - Private (Blank)
- *SOURCE: BLM 2016
- Land Management**
- National Wilderness Area
- Western Pond Turtle Data**
- Western Pond Turtle Habitat



SOUTHERN CALIFORNIA EDISON
An EDISON INTERNATIONAL® Company

FERC Project No. 298
Map AQ 7-2

Western Pond Turtle Habitat



Date: 5/9/2019



Projection: UTM Zone 11
Datum: NAD 83

Southern California Edison (SCE) has no reason to believe that there are any inaccuracies or defects with information incorporated in this work and make no representations of any kind, including, but not limited to, the warranties of merchantability or fitness for a particular use, nor are any such warranties to be implied, with respect to the information or data, furnished herein. No part of this map may be reproduced or transmitted in any form or by any means, electronic or mechanical, including photocopying and recording system, except as expressly permitted in writing by SCE.

Copyright 2019 by Southern California Edison Company

This Page Intentionally Left Blank

Appendix A

Survey Datasets

This Page Intentionally Left Blank

Table A-1. Locations, Conditions and Dates of Searches for Foothill Yellow-Legged Frogs

Study/ Reference Reaches	River	Stream Type, Flow Status P=Project R=Ref	Date	Survey #	Start of Survey					End of Survey					Survey Location				Habitat Notes	Observer 1	Observer 2
					Time	Air Temp (°C)	Water Temp (°C)	Wind Speed (mph)	Light Level	Time	Air Temp (°C)	Water Temp (°C)	Wind Speed (mph)	Light Level	Downstream Latitude	Downstream Longitude	Upstream Latitude	Upstream Longitude			
Marble Fork and Middle Fork Kaweah Rivers (Qualitative)	Marble Fork and Middle Fork Kaweah Rivers (Qualitative)	Tributaries, R	4/23/2018	1	10:50 AM	16	12	5	Sunny	12:30 PM	21	12	5	Sunny	36.511347	-118.80219	36.51609	-118.80155	--	S Kupferberg	R Stoddard
KR US PH3	Kaweah River	Mainstem, R	4/23/2018	1	12:20 PM	18	12	3	Sunny	3:00 PM	18	12	5	Sunny	36.490431	-118.82295	36.49188	-118.82311	--	S Kupferberg	R Stoddard
KR US PH3 - Trib	Unnamed Tributary, Ash Mountain Visitor Center	Tributary, R	5/25/2018	2	10:45 AM	17	12	0-5	Cloudy	1:00 PM	15	11.5	0-5	Cloudy	36.479134	-118.83779	36.48423	-118.83563	--	S Kupferberg	A Adams
KR US PH3	Kaweah River	Mainstem, R	5/27/2018	2	3:15 PM	25	13.5	0-5	Full sun	6:00 PM	24	14	0-5	Sunny	36.488583	-118.82573	36.49339	-118.82562	Mostly bedrock, little habitat except one pool at upstream extent	S Kupferberg	A Adams
KR US PH3	Kaweah River	Mainstem, R	9/10/2018	3	3:00 PM	31	22.2	5-10	Full sun	6:00 PM	22	22	0	Sunny	36.479134	-118.83779	36.48423	-118.83563	--	S Kupferberg	A Arvalo
KR US CONF EF	Kaweah River	Mainstem, P	5/25/2018	2	10:45 AM	17	12	0-3	Cloudy	1:00 PM	15	11.5	0-3	Full sun	36.481676	-118.83760	36.48423	-118.83563		S Kupferberg	A Adams
KR US CONF EF	Kaweah River	Mainstem, P	9/11/2018	3	10:00 AM	29.5	20	0-3	Full sun	12:30 PM	32	20.5	0-3	Full sun	36.481676	-118.83760	36.48423	-118.83563	Both banks wadeable at summer low flow	S Kupferberg	A Arvalo
KR US PH1	Kaweah River	Mainstem, P	9/12/2018	3	3:30 PM	29	23.3	3-5	Sunny	4:20 PM	29	23.3	5	Mostly sun	36.478388	-118.84370	36.47914	-118.83863	Shallow pool margins have good habitat for FYLF tadpoles at summer base flow	S Kupferberg	A Arvalo
KR US PH1	Kaweah River	Mainstem, P	4/24/2018	1	1:30 PM	18	14	--	Full sun	2:30 PM	18	14	0-3	Full sun	36.476994	-118.84784	36.47766	-118.84540	--	S Kupferberg	R Stoddard
KR US PH1 - Trib	Unnamed Tributary on Doos Property	Tributary, R	4/24/2018	1	2:40 PM	19	16	0-3	Full sun	3:50 PM	--	--	0-3	Full sun	36.476994	-118.84784	36.47991	-118.84687	Step pools and small riffles	S Kupferberg	R Stoddard
KR US PH1	Kaweah River	Mainstem, P	5/26/2018	2	10:00 AM	20.5	11	3-5	Partly cloudy	11:46 AM	16	11.5	0-3	Full sun	36.475496	-118.85217	36.47901	-118.84337	Side channel suitable for FYLF breeding but dries before FYLF metamorphosis	S Kupferberg	A Adams
KR US PH1 - Trib	Unnamed Tributary on Doos Property	Tributary, R	5/26/2018	2	12:40 PM	17.5	11	3-5	Partly cloudy	3:00 PM	17.5	16.5	0-3	Cloudy	36.476994	-118.84784	36.48080	-118.84726	Pools in trib disconnected, dry or very shallow in between the pools	S Kupferberg	A Adams
KR US PH1	Kaweah River	Mainstem, P	9/13/2018	3	9:00 AM	25	17.8	5-10	Sunny	2:00 PM	29	22.2	--	Sunny	36.472220	-118.85755	36.47494	-118.85316	Where one would expect to find FYLF, we found bullfrog tadpoles	S Kupferberg	A Arvalo
KR US PH1 - Trib	Unnamed Tributary on Doos Property	Tributary, R	9/13/2018	3	10:09 AM	18	dry - not surveyed	--	Sunny	--	18	--	0-3	Full sun	36.477925	-118.84771	36.48080	-118.84726	Dry channel	S Kupferberg	A Arvalo
KR US PH1	Kaweah River	Mainstem, P	5/25/2018	2	4:26 PM	17.5	12.5	3-5	Cloudy	6:15 PM	18.5	12	0-3	Indirect sun	36.465586	-118.86165	36.47179	-118.85914	Cobble bar at upstream extent had habitat suitable at all flows	S Kupferberg	A Adams
KR US PH2	Kaweah River	Mainstem, P	5/26/2018	2	4:55 PM	19	12.5	3-5	Cloudy	6:15 PM	18	12.5	0-5	Shade	36.463247	-118.87224	36.46063	-118.87139	Midchannel islands with riparian vegetation	S Kupferberg	A Adams

Study/ Reference Reaches	River	Stream Type, Flow Status P=Project R=Ref	Date	Survey #	Start of Survey					End of Survey					Survey Location				Habitat Notes	Observer 1	Observer 2
					Time	Air Temp (°C)	Water Temp (°C)	Wind Speed (mph)	Light Level	Time	Air Temp (°C)	Water Temp (°C)	Wind Speed (mph)	Light Level	Downstream Latitude	Downstream Longitude	Upstream Latitude	Upstream Longitude			
KR US PH2	Kaweah River	Mainstem, P	9/13/2018	3	1:45 PM	27.8	18.9	--	Sunny	2:50 PM	28.3	19.4	5	Sunny	36.474945	-118.85316	36.46063	-118.87139	Side channel river left with many 1st year bullfrog tadpoles all <20 mm	S Kupferberg	A Adams
KR US PH2 - Trib	Salt Creek	Tributary, R	4/24/2018	1	9:40 AM	16	16	0-3	Canyon in shade	11:40 AM	18	16	0-3	Sunny	36.459340	-118.87145	36.45800	-118.87190	Pools would be good habitats for adult FYLF	S Kupferberg	R Stoddard
KR US PH2	Kaweah River	Mainstem, P	5/26/2018	2	6:30 PM	26	18	0-3	Shady	7:10 PM	23	18	0-3	Shady	36.459340	-118.87145	36.45800	-118.87190	Pools becoming disconnected	S Kupferberg	A Adams
KR US PH2 - Trib	Salt Creek	Tributary, R	9/13/2018	3	2:30 PM	27.8	dry - not surveyed	0-3	Sunny	--	--	--	--	--	36.459340	-118.87145	36.45800	-118.87190	Creek was dry, not sampled	S Kupferberg	A Arvalo
North Fork Kaweah River	North Fork Kaweah River	Tributary, R	5/27/2018	2	12:00 PM	27	12.5	0-3	Full sun	1:35 PM	28	12.5	0-3	Full sun	36.461493	-118.88249	36.45891	-118.87790	Split channel	S Kupferberg	A Adams
KR US PH2	Kaweah River	Mainstem, P	9/14/2018	3	9:00 AM	20	17.8	0	Sunny	12:20 PM	29	20	10	Sunny	36.456088	-118.88955	36.45891	-118.87790	Split channel	S Kupferberg	A Arvalo
North Fork Kaweah River	North Fork Kaweah River	Tributary, R	9/13/2018	3	3:30 PM	28.9	23.3	5	Sunny	4:40 PM	29	23	0	Shaded	36.464124	-118.91273	36.46608	-118.91149	Dense canopy, low gradient, riffle-pool sequences with some depositional habitat	S Kupferberg	A Arvalo
EF DS K1 DIV - Trib	Unnamed Creek	Tributary, R	5/24/2018	2	11:30 AM	25	15	0-5	Full Sun	3:00 PM	20	15.5	0-5	Sunny	36.450446	-118.79670	36.45474	-118.78824	Creek is mostly shaded	S Kupferberg	A Adams
EF US K1 DIV - Trib	Unnamed Creek	Tributary, R	5/24/2018	2	4:00 PM	21	14.5	0-5	Cloudy	5:15 PM	21	14.5	0-5	Cloudy	36.448139	-118.77308	36.44988	-118.77233	Suitable for newt, treefrog breeding, not FYLF, could be adult / juvenile habitat	S Kupferberg	A Adams
EF US K1 DIV	East Fork Kaweah River	Mainstem, R	5/24/2018	2	--	--	--	--	--	--	--	--	--	--	--	--	--	--	Inaccessible due to high flow, viewed from bank	--	--
EF DS K1 DIV - Trib	Unnamed Tributary A	Tributary, R	9/12/2018	3	8:30 AM	--	dry - not surveyed	--	--	--	--	--	--	--	36.448140	-118.77308	--	--	--	S Kupferberg	A Arvalo
EF US K1 DIV - Trib	Unnamed Tributary B	Tributary, R	9/12/2018	3	9:00 AM	--	dry - not surveyed	--	--	--	--	--	--	--	36.451856	-118.78984	--	--	--	S Kupferberg	A Arvalo
EF US K1 DIV	East Fork Kaweah River	Mainstem, R	9/12/2018	3	9:50 AM	21	15.5	0-3	Canyon in shade	11:30 AM	24	16	0-3	Sunny	36.451761	-118.78926	36.44996	-118.78792	--	S Kupferberg	A Arvalo
EF DS K1 DIV	East Fork Kaweah River	Mainstem, P	5/24/2018	2	5:00 PM	22	12	0-5	Cloudy	5:50 PM	22	12	0-5	Cloudy	36.450446	-118.79670	36.45033	-118.79597	Bedrock canyon, too swift to wade, walked margins	S Kupferberg	A Adams
EF DS K1 DIV	East Fork Kaweah River	Mainstem, P	9/12/2018	3	1:00 PM	23.9	15.5	0-3	Full Sun	2:45 PM	25	17	0-5	Sunny	36.450446	-118.79670	36.45151	-118.78981	Turbulent flows at summer base flow discharge, not suitable for amphibians	S Kupferberg	A Arvalo
EF US CONF KR - Trib	Unnamed Tributary C	Tributary, R	5/28/2018	2	10:15 AM	22	14	0-5	Sunny	10:45 AM	22	14	0-5	Sunny	36.476528	-118.83468	36.47674	-118.83409	Remnant pools ≤20 cm deep, <i>Mougeotia</i> (mucilaginous filamentous green alga)	--	--
EF US CONF KR	East Fork Kaweah River	Mainstem, P	5/28/2018	2	9:30 AM	22	14	5	Sunny	1:00 PM	26	14.5	5	Full sun	36.479134	-118.83779	36.47551	-118.83370	Pool tailouts in this bedrock reach offer sparse breeding habitat for FYLF	S Kupferberg	A Adams

Study/ Reference Reaches	River	Stream Type, Flow Status P=Project R=Ref	Date	Survey #	Start of Survey					End of Survey					Survey Location				Habitat Notes	Observer 1	Observer 2
					Time	Air Temp (°C)	Water Temp (°C)	Wind Speed (mph)	Light Level	Time	Air Temp (°C)	Water Temp (°C)	Wind Speed (mph)	Light Level	Downstream Latitude	Downstream Longitude	Upstream Latitude	Upstream Longitude			
EF US CONF KR - Trib	Unnamed Tributary C	Tributary, P	9/11/2018	3	--	--	dry - not surveyed	--	--	--	--	--	--	--	--	--	--	--	Dry - not surveyed	--	--
EF US CONF KR	East Fork Kaweah River	Mainstem, P	9/11/2018	3	1:20 PM	33.3	20.6	0-3	Full sun	3:36 PM	32	21	0-5	Full sun	36.479108	-118.83811	36.47348	-118.83451	Western pearl shell mussels in low gradient pools near confluence with Kaweah	--	--

This Page Intentionally Left Blank

Table A-2. Descriptions of Physical Habitat Conditions in Surveyed Reaches

Study/ Reference Reaches	River	Stream Type, Flow Status P=Project R=Ref	Latitude	Longitude	Date	Meso Habitat	Suitable for FYLF (Y/N)	FYLF lifestage	Patch Size for FYLF breeding (m ²)	Suitable for EMMA (Y/N)	Nest Habitat Nearby (Y/N)	Notes
Marble Fork and Middle Fork Kaweah Rivers (Qualitative)	Marble Fork and Middle Fork Kaweah Rivers (Qualitative)	Tributaries, R	36.51284	-118.80042	4/23/2018	Margins Of Runs	Y	All	4	Y	Y	Rainbow trout spawning in gravels at tail out
Marble Fork and Middle Fork Kaweah Rivers (Qualitative)	Marble Fork and Middle Fork Kaweah Rivers (Qualitative)	Tributaries, R	36.51609	-118.80155	4/23/2018	Margins Of Runs	Y	Adults, Juveniles	--	N	N	Qualitative sites near Potwisha C.G.
Marble Fork and Middle Fork Kaweah Rivers (Qualitative)	Marble Fork and Middle Fork Kaweah Rivers (Qualitative)	Tributaries, R	36.51630	-118.80086	4/23/2018	Downstream Of Footbridge, Margins <1M Band Low Velocity	Y	Adults, Juveniles	--	N	N	Qualitative sites near Potwisha C.G.
Marble Fork and Middle Fork Kaweah Rivers (Qualitative)	Marble Fork and Middle Fork Kaweah Rivers (Qualitative)	Tributaries, R	36.51346	-118.80052	4/23/2018	Channel Margin With Small Patches Suitable Habitat	Y	All	20	N	N	Qualitative sites near Potwisha C.G.
Marble Fork and Middle Fork Kaweah Rivers (Qualitative)	Marble Fork and Middle Fork Kaweah Rivers (Qualitative)	Mainstem, R	36.51135	-118.80219	4/23/2018	Confluence Overlook	Y	All	3.5	N	N	Qualitative site
Marble Fork and Middle Fork Kaweah Rivers (Qualitative)	Marble Fork and Middle Fork Kaweah Rivers (Qualitative)	Tributaries, R	36.51501	-118.80164	4/23/2018	Sidechannel With Cattails	N	--	--	N	N	Qualitative site, velocities too high at confluence at peak flows for FYLF and EMMA
KR US PH3	Kaweah River	Mainstem, R	36.49116	-118.82209	9/10/2018	Side Pools	Y	All	4	Y	Y	Damselfly nymphs, Lestes sp.
KR US PH3	Kaweah River	Mainstem, R	36.49082	-118.82268	4/23/2018	Pool Tail Out	Y	All	17	Y	N	--
KR US PH3	Kaweah River	Mainstem, R	36.48858	-118.82573	5/27/2018	Pool Tail Out	Y	Egg	4	N	N	Bedrock rapids with little suitable FYLF habitat except for pool tailouts
KR US PH3	Kaweah River	Mainstem, R	36.48889	-118.82448	5/27/2018	Pool Tail Out	Y	Egg	4	Y	N	--
KR US PH3	Kaweah River	Mainstem, R	36.48985	-118.82330	5/27/2018	Pool Tail Out	Y	Egg	4	N	N	Bedrock rapids with little suitable FYLF habitat except for pool tailouts
KR US PH3	Kaweah River	Mainstem, R	36.49201	-118.82318	5/27/2018	Pool Tail Out	Y	Adult, Egg	5	Y	Y	Pool less than 2 m deep, low turbulence, max velocity 60 cm/sec, cobble patches at margins and tail out
KR US PH3	Kaweah River	Mainstem, R	36.48025	-118.83782	9/10/2018	Channel Margins	Y	All	8	Y	Y	Mergansers and dippers
KR US PH3	Kaweah River	Mainstem, R	36.49135	-118.82269	5/27/2018	Confluence with smaller stream	Y	Adult, Egg	5	N	N	Two small patches of habitat on both banks, mid-channel island has rapids on both sides
KR US PH3	Kaweah River	Mainstem, R	36.49103	-118.82221	4/23/2018	Margin Of Rapids	N	--	--	N	N	--
KR US PH3	Kaweah River	Mainstem, R	36.49188	-118.82311	4/23/2018	Margin Of Rapids	N	--	--	N	N	--

Study/ Reference Reaches	River	Stream Type, Flow Status P=Project R=Ref	Latitude	Longitude	Date	Meso Habitat	Suitable for FYLF (Y/N)	FYLF lifestage	Patch Size for FYLF breeding (m ²)	Suitable for EMMA (Y/N)	Nest Habitat Nearby (Y/N)	Notes
KR US PH3	Kaweah River	Mainstem, R	36.49103	-118.82221	4/23/2018	Margin Of Rapids	N	--	--	N	N	--
KR US PH3	Kaweah River	Mainstem, R	36.49783	-118.81983	4/23/2018	Ephemeral Tributary Drainage	N	--	--	N	N	--
KR US PH3 - Trib	Kaweah River	Tributary, R	36.48778	-118.83637	5/25/2018	Confluence With An Ephemeral Tributary	N	--	--	N	N	--
KR US PH3	Kaweah River	Mainstem, P	36.48740	-118.83591	5/25/2018	Channel Margin Of Large Pool / Forebay	N	--	--	N	N	--
KR US PH3	Kaweah River	Mainstem, P	36.48665	-118.83622	5/25/2018	Bedrock Pools/ Cascades	N	--	--	N	N	--
KR US PH3	Kaweah River	Mainstem, R	36.48852	-118.82628	9/10/2018	Bedrock	N	--	--	N	N	Gradient becomes steeper downstream from this pool
KR US PH3	Kaweah River	Mainstem, R	36.48853	-118.82625	9/10/2018	Bedrock	N	--	--	N	N	Scour holes completely dry no frogs found in vicinity
KR US PH3	Kaweah River	Mainstem, R	36.48848	-118.82529	9/10/2018	Shaded Run	N	--	--	N	N	Potholes completely dry no frogs found in vicinity
KR US PH3 - Trib	Unnamed Tributary, Ash Mountain Visitor Center	Tributary, R	36.49208	-118.82504	4/23/2018	Runs, 2 M Wide	Y	Adults, Juveniles	--	N	N	--
KR US PH3 - Trib	Unnamed Tributary, Ash Mountain Visitor Center	Tributary, R	36.49180	-118.82464	4/23/2018	Pool	Y	Adults, Juveniles	--	N	N	--
KR US PH3 - Trib	Unnamed Tributary, Ash Mountain Visitor Center	Tributary, R	36.49038	-118.82283	4/23/2018	Confluence Salt Creek With Side Channel Of Kaweah, Overgrown	Y	Adults, Juveniles	--	N	N	Small fish observed in pool so potentially this part of Salt Creek has perennial flow
KR US PH3 - Trib	Unnamed Tributary, Ash Mountain Visitor Center	Tributary, R	36.49030	-118.82277	4/23/2018	Sidepool, Boulders Over Sand	Y	Adults, Juveniles	--	N	N	--
KR US CONF EF	Kaweah River	Mainstem, P	36.48188	-118.83755	5/25/2018	Riffle Margins	Y	All	49	N	N	Depth 120 cm, 7 m diameter patch of habitat, boulder over sand
KR US CONF EF	Kaweah River	Mainstem, P	36.48359	-118.83715	5/25/2018	Pool Margin	Y	All	4	--	--	--
KR US CONF EF	Kaweah River	Mainstem, P	36.48397	-118.83615	9/11/2018	Margins Of Runs	Y	All	10	Y	N	--
KR US CONF EF	Kaweah River	Mainstem, P	36.48231	-118.83752	5/25/2018	Side Pool	Y	Adult, Eggmasses	27	N	N	Patch of low velocity habitat 5 m long by 8 m wide of potential breeding habitat
KR US CONF EF	Kaweah River	Mainstem, P	36.48334	-118.83745	5/25/2018	Margins Of Runs	N	--	--	N	N	very sandy bottom, 12 m diameter
KR US CONF EF	Kaweah River	Mainstem, P	36.48238	-118.83753	5/25/2018	Large Boulders And Bedrock	N	--	--	N	N	Calm velocities but depths too shallow, less than 15 cm, will dry as flows recedes
KR US CONF EF	Kaweah River	Mainstem, P	36.47881	-118.83968	4/23/2018	Boulder, Bedrock Rapids, Very Narrow Margin Along Banks With Slow Velocity	N	--	--	N	N	High gradient cascades

Study/ Reference Reaches	River	Stream Type, Flow Status P=Project R=Ref	Latitude	Longitude	Date	Meso Habitat	Suitable for FYLF (Y/N)	FYLF lifestage	Patch Size for FYLF breeding (m ²)	Suitable for EMMA (Y/N)	Nest Habitat Nearby (Y/N)	Notes
KR US CONF EF	Kaweah River	Mainstem, P	36.48168	-118.83760	5/25/2018	Bedrock Wall On River Right Below Flume	N	--	--	N	N	--
KR US CONF EF	Kaweah River	Mainstem, P	36.48250	-118.83746	9/11/2018	Bedrock Cascade	N	--	--	N	N	Scour holes in bedrock previously occupied by treefrogs now dry
KR US CONF EF	Kaweah River	Mainstem, P	36.48423	-118.83563	5/25/2018	Pool	N	--	--	N	N	End of wadeable reach
KR US PH1	Kaweah River	Mainstem, P	36.47678	-118.84681	4/24/2018	Pool, Bedrock On River Right	Y	Adults	--	Y	Y	Main channel all rapids, no FYLF breeding sites
KR US PH1	Kaweah River	Mainstem, P	36.47953	-118.84047	9/12/2018	Tributary	N	--	--	Y	Y	--
KR US PH1 - Trib	Kaweah River	Tributary, R	36.47708	-118.84759	9/13/2018	Stranded Side Pool	N	--	--	N	N	Tributary completely dry, no flow
KR US PH1	Kaweah River	Mainstem, P	36.47704	-118.84771	4/24/2018	Step Poole	N	--	--	N	N	--
KR US PH1	Kaweah River	Mainstem, P	36.47713	-118.84785	5/26/2018	Stagnant Side Pool	N	--	--	N	N	Most upstream pool with water
KR US PH1	Kaweah River	Mainstem, P	36.47863	-118.84374	9/13/2018	Sidepool, Stagnant And Shady	N	--	--	N	N	--
KR US PH1	Kaweah River	Mainstem, P	36.47550	-118.85217	5/26/2018	Side Pool With Some Flow	N	--	--	N	N	Pool dimension 40 m long x 8.5 m wide, too shady for turtles to bask
KR US PH1	Kaweah River	Mainstem, P	36.47691	-118.84930	5/26/2018	Side Pool With Some Flow	N	--	--	Y	Y	Sandy soil on bank might be too loose for turtle nests
KR US PH1	Kaweah River	Mainstem, P	36.47910	-118.84359	5/26/2018	Side Channel	N	--	--	Y	Y	Pool is 60 m long x 15 m wide
KR US PH1	Kaweah River	Mainstem, P	36.46325	-118.87224	5/26/2018	Pool	N	--	--	Y	N	--
KR US PH1	Kaweah River	Mainstem, P	36.47649	-118.84625	9/13/2018	Pool	N	--	--	Y	Y	Bottom of pool is very sandy
KR US PH1	Kaweah River	Mainstem, P	36.47914	-118.83863	9/12/2018	Midchannel Island, Downstream Extent	N	--	--	N	N	--
KR US PH1	Kaweah River	Mainstem, P	36.45953	-118.87325	5/26/2018	Midchannel Island, Cobbles	N	--	--	N	N	--
KR US PH1	Kaweah River	Mainstem, P	36.45965	-118.87285	5/26/2018	Midchannel Island, Cobbles	N	--	--	N	N	--
KR US PH1	Kaweah River	Mainstem, P	36.45999	-118.87217	5/26/2018	Midchannel Island	N	--	--	N	N	--
KR US PH1	Kaweah River	Mainstem, P	36.46042	-118.87143	5/26/2018	Margins Of Riffels / Split Channel	N	--	--	N	N	For FYLF velocities too swift flowing through the vegetation on island
KR US PH1	Kaweah River	Mainstem, P	36.46561	-118.86166	5/25/2018	Margins Of Riffels / Split Channel	N	--	--	N	N	--
KR US PH1	Kaweah River	Mainstem, P	36.46559	-118.86165	5/25/2018	Large Pool	N	--	--	N	N	--
KR US PH1	Kaweah River	Mainstem, P	36.47766	-118.84540	4/24/2018	Large Pool	N	--	--	N	N	Ended Survey at upstream location due to difficulty with access at survey flows
KR US PH1	Kaweah River	Mainstem, P	36.48108	-118.84244	4/24/2018	Large Pool	N	--	--	N	N	Bullfrog pond
KR US PH1	Kaweah River	Mainstem, P	36.45641	-118.78542	5/24/2018	Isolated Side Pool	N	--	--	N	N	--
KR US PH1	Kaweah River	Mainstem, P	36.47728	-118.84558	5/26/2018	Intermittent Pools	N	--	--	Y	Y	Large boulders with overhangs
KR US PH1	Kaweah River	Mainstem, P	36.48080	-118.84726	5/26/2018	End Of Side Channel Habitat, Continuous Rapids	N	--	--	N	N	Tributary drying, max depths ≤10 cm
KR US PH1	Kaweah River	Mainstem, P	36.47725	-118.84566	4/24/2018	Deep Pool	N	--	--	--	--	--

Study/Reference Reaches	River	Stream Type, Flow Status P=Project R=Ref	Latitude	Longitude	Date	Meso Habitat	Suitable for FYLF (Y/N)	FYLF lifestage	Patch Size for FYLF breeding (m ²)	Suitable for EMMA (Y/N)	Nest Habitat Nearby (Y/N)	Notes
KR US PH1	Kaweah River	Mainstem, P	36.47302	-118.85616	9/13/2018	Confluence Between Side Creek And Mainstem	N	--	--	Y	Y	--
KR US PH1	Kaweah River	Mainstem, P	36.47699	-118.84784	4/24/2018	Confluence	N	--	--	N	N	Tributary confluence
KR US PH1	Kaweah River	Mainstem, P	36.48022	-118.83797	9/12/2018	Channel Margin	N	--	--	N	N	--
KR US PH1	Kaweah River	Mainstem, P	36.46210	-118.87167	5/26/2018	Channel Margin	N	--	--	N	N	Riparian vegetation encroachment (non-native spp. = grapes, Scotch Broom, mulberry tree)
KR US PH1	Kaweah River	Mainstem, P	36.46063	-118.87139	5/26/2018	Cascades	N	--	--	N	N	--
KR US PH1	Kaweah River	Mainstem, P	36.47825	-118.84423	9/13/2018	Shallow Pool	N	--	--	N	N	--
KR US PH1 - Trib	Unnamed Tributary on Doos Property	Tributary, R	36.47727	-118.84785	4/24/2018	Shallow Glide	Y	Adults, Juveniles	--	N	N	--
KR US PH1 - Trib	Unnamed Tributary on Doos Property	Tributary, R	36.47746	-118.84785	4/24/2018	Dry Channel	N	--	--	N	N	Only 5 cm deep, shady sycamore and oak canopy
KR US PH1 - Trib	Unnamed Tributary on Doos Property	Tributary, R	36.47729	-118.84783	4/24/2018	Culvert	N	--	--	N	N	--
KR US PH1 - Trib	Unnamed Tributary on Doos Property	Tributary, R	36.47799	-118.84779	4/24/2018	Willows At Margin, Low Velocity Edge Of Riffle	N	--	--	N	N	Stream crosses under a dirt road
KR US PH1	Kaweah River	Mainstem, P	36.46995	-118.86048	5/26/2018	Stranded Side Pool	Y	All	3	N	N	--
KR US PH1	Kaweah River	Mainstem, P	36.47749	-118.84558	4/24/2018	Side Channel, River Right	Y	Adults, Juveniles	--	Y	Y	--
KR US PH1	Kaweah River	Mainstem, P	36.47692	-118.84566	9/13/2018	Side Channel, River Right	Y	All	18	Y	Y	Canopy opens, more sun hitting side channel
KR US PH1	Kaweah River	Mainstem, P	36.47690	-118.84576	9/13/2018	Side Channel	Y	Adults, Juveniles	22	N	N	Very shady, probably not good for oviposition or turtle basking
KR US PH1	Kaweah River	Mainstem, P	36.47862	-118.84402	5/26/2018	Side Channel	Y	Eggs	6	N	N	--
KR US PH1	Kaweah River	Mainstem, P	36.47901	-118.84337	5/26/2018	Side Channel	Y	Eggs	6	N	N	--
KR US PH1	Kaweah River	Mainstem, P	36.46565	-118.86164	4/23/2018	Side Channel	Y	Adults, Juveniles	--	N	N	At high flows side channel flowing, narrow margin of low velocity, dry at baseflow
KR US PH1	Kaweah River	Mainstem, P	36.46581	-118.86143	4/23/2018	Shallow Pool	Y	Adults, Juveniles	--	N	N	--
KR US PH1	Kaweah River	Mainstem, P	36.47918	-118.83971	9/12/2018	Shallow Pool	Y	Tadpoles	25	Y	Y	--
KR US PH1	Kaweah River	Mainstem, P	36.47911	-118.83889	9/12/2018	Riffle Through Willows	Y	Tadpoles	25	Y	Y	Any turtle nesting habitat would be on river right. River left is next to road and very developed
KR US PH1	Kaweah River	Mainstem, P	36.47652	-118.84632	5/26/2018	Pool With Large Boulders	Y	Adults, Eggs	1	N	N	<1 m ² patches of low velocity for FYLF eggs on lee sides of cobbles, depth 20 - 30 cm, but dry at baseflow
KR US PH1	Kaweah River	Mainstem, P	36.47686	-118.84572	5/26/2018	Pocket Water	Y	Adults, Eggs	29	Y	Y	Perimeter of pool would be suitable, pool dimension 9 x 12 m, 2 m deep at center

Study/ Reference Reaches	River	Stream Type, Flow Status P=Project R=Ref	Latitude	Longitude	Date	Meso Habitat	Suitable for FYLF (Y/N)	FYLF lifestage	Patch Size for FYLF breeding (m ²)	Suitable for EMMA (Y/N)	Nest Habitat Nearby (Y/N)	Notes
KR US PH1	Kaweah River	Mainstem, P	36.47835	-118.84420	5/26/2018	Midchannel Islands With Low Flow Patches	Y	Eggs	4.5	N	N	Slow velocity water at margin of a rapid that might stay wet / connected to main channel as flows recede
KR US PH1	Kaweah River	Mainstem, P	36.47060	-118.86071	5/26/2018	Midchannel Island, Cobbles	Y	All	2	N	N	--
KR US PH1	Kaweah River	Mainstem, P	36.46086	-118.87103	5/26/2018	Midchannel Island / Cobble Bar	y	Eggs	30	N	N	Narrow margin along this part of island with low enough velocities for oviposition
KR US PH1	Kaweah River	Mainstem, P	36.47643	-118.84650	9/13/2018	Midchannel Island	Y	All	16	N	N	--
KR US PH1	Kaweah River	Mainstem, P	36.46261	-118.87198	5/26/2018	Edgewater	Y	Eggs	30	N	N	Patch of low velocity habitat along right bank (island dimensions 30 x 7 m)
KR US PH1	Kaweah River	Mainstem, P	36.47600	-118.85100	5/26/2018	Confluence With Tributary Creek, Boulders With Pockets Of Slow Velocity Water On Margin	Y	Eggs	2	N	N	Boulders over sand
KR US PH1	Kaweah River	Mainstem, P	36.47793	-118.84771	9/13/2018	Cobble/ Boulder Bars That Look Like Habitat From A Distance, Flows Too High To Cross	Y	All	4	N	N	--
KR US PH1	Kaweah River	Mainstem, P	36.47993	-118.83778	4/23/2018	Cobble/ Boulder Bars That Look Like Habitat From A Distance, Flows Too High To Cross	Y	All	--	N	N	--
KR US PH1	Kaweah River	Mainstem, P	36.49468	-118.82317	4/23/2018	Cobble/ Boulder Bars That Look Like Habitat From A Distance, Flows Too High To Cross	Y	All	--	N	N	--
KR US PH1	Kaweah River	Mainstem, P	36.49778	-118.81981	4/23/2018	Cobble Bar, And Side Channel	Y	All	--	N	N	--
KR US PH1	Kaweah River	Mainstem, P	36.47662	-118.84550	9/13/2018	Cobble Bar River Left	Y	All	22	Y	Y	--
KR US PH1	Kaweah River	Mainstem, P	36.47789	-118.84529	5/26/2018	Cobble Bar River Left	Y	All	15	Y	N	Residence with steps leading down to river,
KR US PH1	Kaweah River	Mainstem, P	36.47179	-118.85914	5/26/2018	Cobble Bar / Pool Tail Out	Y	All	50	Y	Y	Private property, landowner gave us permission to hike out of channel across his land
KR US PH1	Kaweah River	Mainstem, P	36.47748	-118.84521	9/13/2018	Cobble Bar	Y	All	18	N	N	Habitat on left bank only, right bank rock wall
KR US PH1	Kaweah River	Mainstem, P	36.47256	-118.85667	9/13/2018	Cobble At Margin Of Low Velocity Pool	y	All	25	Y	Y	At transect #1 of flow study
KR US PH1	Kaweah River	Mainstem, P	36.46846	-118.86005	5/25/2018	Cobble And Boulder Split Channel On River Left	Y	All	3	N	N	--
KR US PH1	Kaweah River	Mainstem, P	36.46663	-118.86046	5/25/2018	Cobble And Boulder Bar On River Right With Willows	Y	All	25	N	N	This side channel probably does not flow at lower discharges
KR US PH1	Kaweah River	Mainstem, P	36.46539	-118.86296	4/23/2018	Confluence	Y	Adults, Juveniles	--	N	N	If eggs laid on cobble bar at high flows, tadpoles would be stranded
KR US PH2	Kaweah River	Mainstem, P	36.45891	-118.87790	5/27/2018	Cobble Bar	Y	All	8	N	N	Cobbles and boulders on river left downstream of Dinely Rd bridge

Study/ Reference Reaches	River	Stream Type, Flow Status P=Project R=Ref	Latitude	Longitude	Date	Meso Habitat	Suitable for FYLF (Y/N)	FYLF lifestage	Patch Size for FYLF breeding (m ²)	Suitable for EMMA (Y/N)	Nest Habitat Nearby (Y/N)	Notes
KR US PH2	Kaweah River	Mainstem, P	36.45934	-118.87145	9/13/2018	Step Pools	N	--	--	N	N	Salt Creek is dry at confluence, no water in first several pools
KR US PH2 - Trib	Salt Creek	Tributary, R	36.46013	-118.87150	4/24/2018	Step Pools	Y	Adults, Juveniles	--	Y	N	--
KR US PH2 - Trib	Salt Creek	Tributary, R	36.46028	-118.87136	4/24/2018	Pool, Sandy Bottom, Cattails, 10 M Diam, 0.9 M Deep	Y	Adults, Juveniles	--	Y	N	--
KR US PH2 - Trib	Salt Creek	Tributary, R	36.45896	-118.87207	4/24/2018	Pool	Y	Adults, Juveniles	--	Y	Y	Good habitat for turtles
KR US PH2 - Trib	Salt Creek	Tributary, R	36.45800	-118.87190	4/24/2018	Ephemeral Tributary, Cobble Area	Y	Adults, Juveniles	--	Y	N	Good habitat for adult FYLF, 10m x 4m pool
KR US PH2 - Trib	Salt Creek	Tributary, P	36.45963	-118.87153	4/24/2018	Side Channel	Y	All	10	N	N	--
KR DS PH2	Kaweah River	Mainstem, P	36.45669	-118.88994	9/14/2018	Overflow Side Channels	Y	All	10	N	N	Rocks with epiphytized Cladophora in pocket water
KR DS PH2	Kaweah River	Mainstem, P	36.46089	-118.88444	9/14/2018	Mid-Channel Island	Y	All	35	N	N	--
KR DS PH2	Kaweah River	Mainstem, P	36.46164	-118.88185	5/27/2018	Cobble Bar, Island With Willows	Y	All	20	N	N	Suitable depths and velocities through the vegetation on the island, but dries at base flow
KR DS PH2	Kaweah River	Mainstem, P	36.46028	-118.88654	9/14/2018	Cobble Bar	Y	All	20	N	N	--
KR DS PH2	Kaweah River	Mainstem, P	36.46121	-118.88322	9/14/2018	Midchannel Cattails, Upturned Alder	Y	All	30	N	N	--
KR DS PH2	Kaweah River	Mainstem, P	36.46101	-118.88524	9/14/2018	Margin, Rapid / Riffle	N	--	--	N	N	--
KR DS PH2	Kaweah River	Mainstem, P	36.46173	-118.88145	5/27/2018	Margin, Rapid / Riffle	N	--	--	N	N	Channel splits survey on river right
KR DS PH2	Kaweah River	Mainstem, P	36.46162	-118.88066	5/27/2018	Margin, Rapid / Riffle	N	--	--	N	N	--
KR DS PH2	Kaweah River	Mainstem, P	36.46119	-118.88001	5/27/2018	Deep Pool	N	--	--	N	N	Right bank too high velocity for FYLF, left bank with cobbles suitable where rafters take out
KR DS PH2	Kaweah River	Mainstem, P	36.45609	-118.88955	9/14/2018	Bedrock, End Of Split Channel	N	--	--	Y	Y	--
KR DS PH2	Kaweah River	Mainstem, P	36.46149	-118.88249	5/27/2018	Run	N	--	--	N	N	--
North Fork Kaweah River	North Fork Kaweah River	Mainstem, R	36.46412	-118.91273	9/13/2018	Pool Tail Out, Confluence Ephemeral Tributary	Y	Adults	--	Y	Y	--
EF US K1 DIV	East Fork Kaweah River	Mainstem, P	36.48061	-118.83514	5/28/2018	Pool	Y	Adult, Egg	5	Y	N	--
EF US K1 DIV	East Fork Kaweah River	Mainstem, R	36.45142	-118.78854	9/12/2018	Moist Seep	Y	All	8	N	N	Shallow margins of pool with cobbles could be suitable, but no large woody debris for turtles
EF US K1 DIV	East Fork Kaweah River	Mainstem, R	36.45157	-118.78855	9/12/2018	Cascades	Y	Adult, Juveniles	--	N	N	--
EF US K1 DIV	East Fork Kaweah River	Mainstem, R	36.45154	-118.78855	9/12/2018	Cascades	N	--	--	N	N	--
EF US K1 DIV	East Fork Kaweah River	Mainstem, R	36.44996	-118.78792	9/12/2018	Cascade Pools	N	--	--	N	N	Impassable bedrock walls and cliffs, end of survey

Study/ Reference Reaches	River	Stream Type, Flow Status P=Project R=Ref	Latitude	Longitude	Date	Meso Habitat	Suitable for FYLF (Y/N)	FYLF lifestage	Patch Size for FYLF breeding (m ²)	Suitable for EMMA (Y/N)	Nest Habitat Nearby (Y/N)	Notes
EF US K1 DIV - Trib	East Fork Kaweah River	Tributary, R	36.45188	-118.78917	5/24/2018	Cascade Pools	Y	Adults	--	N	N	--
EF US K1 DIV - Trib	East Fork Kaweah River	Tributary, R	36.44814	-118.77308	5/24/2018	Shallow Glide Through Thicket	Y	Adults	--	N	N	
EF US K1 DIV - Trib	East Fork Kaweah River	Tributary, R	36.44988	-118.77233	5/24/2018	Confluence With Tributary	N	--	--	N	N	Ended survey here due to impenetrable vegetation
EF DS K1 DIV	East Fork Kaweah River	Mainstem, P	36.45110	-118.79021	9/12/2018	Isolated Scour Pool In Bedrock	Y	All	20	N	N	Tributary dried up, no surface flow
EF DS K1 DIV	East Fork Kaweah River	Mainstem, P	36.45045	-118.79670	9/12/2018	Cascades	N	--	--	N	N	--
EF DS K1 DIV	East Fork Kaweah River	Mainstem, P	36.45060	-118.79044	9/12/2018	Bedrock Pool	N	--	--	N	N	Downstream extent of accessible river to survey
EF DS K1 DIV	East Fork Kaweah River	Mainstem, P	36.45084	-118.79623	9/12/2018	Side Creek That Flows Into E. Fk. Kaweah	N	--	--	N	N	Deep pool in between bedrock cascades, dippers flying up and down channel here
EF DS K1 DIV - Trib	Unnamed Tributary to East Fork Kaweah River	Tributary, R	36.45301	-118.78985	4/24/2018	Dry Channel	Y	Adults, Juveniles	--	N	N	--
EF DS K1 DIV - Trib	Unnamed Tributary to East Fork Kaweah River	Tributary, R	36.45425	-118.79003	5/24/2018	Cascade Pools	Y	Adults	--	N	N	--
EF DS K1 DIV - Trib	Unnamed Tributary to East Fork Kaweah River	Tributary, R	36.45474	-118.78824	5/24/2018	Side Pool	Y	Adults	--	N	N	Western branch of side creek, all cascade step pools
EF US CONF KR	East Fork Kaweah River	Mainstem, P	36.47601	-118.83458	9/11/2018	Pool Tail Out	Y	Adult, Juveniles	--	N	N	--
EF US CONF KR	East Fork Kaweah River	Mainstem, P	36.47785	-118.83566	5/28/2018	Bedrock Crevices	Y	All	7	Y	N	--
EF US CONF KR	East Fork Kaweah River	Mainstem, P	36.47635	-118.83480	5/28/2018	Bedrock	Y	All	10	Y	N	--
EF US CONF KR - Trib	Unnamed Tributary to East Fork Kaweah River	Tributary, P	36.47653	-118.83468	5/28/2018	Confluence Ephemeral Tributary Drainage	Y	Adult, Juveniles	--	N	N	Trickle of water over bedrock in tributary, quickly de-watering
EF US CONF KR	East Fork Kaweah River	Mainstem, P	36.47674	-118.83409	5/28/2018	--	Y	Adult, Juveniles	--	N	N	--
EF US CONF KR	East Fork Kaweah River	Mainstem, P	36.47901	-118.83788	5/28/2018	Seep	N	--	--	N	N	--
EF US CONF KR - Trib	Unnamed Tributary to East Fork Kaweah River	Tributary, P	36.47609	-118.83450	5/28/2018	Pool	N	Juveniles	--	N	N	--

Study/ Reference Reaches	River	Stream Type, Flow Status P=Project R=Ref	Latitude	Longitude	Date	Meso Habitat	Suitable for FYLF (Y/N)	FYLF lifestage	Patch Size for FYLF breeding (m ²)	Suitable for EMMA (Y/N)	Nest Habitat Nearby (Y/N)	Notes
EF US CONF KR	East Fork Kaweah River	Mainstem, P	36.47888	-118.83717	5/28/2018	Cascades	N	--	--	Y	Y	Pool with no turbulence, boulders over sand
EF US CONF KR	East Fork Kaweah River	Mainstem, P	36.47348	-118.83451	9/11/2018	Cascade -Impassable	N	--	--	N	N	End of accessible river to survey
EF US CONF KR	East Fork Kaweah River	Mainstem, P	36.47550	-118.83417	5/28/2018	Bedrock Slot Canyon	N	--	--	N	N	Hike up and around to get past cascade
EF US CONF KR	East Fork Kaweah River	Mainstem, P	36.47551	-118.83370	5/28/2018	Bedrock Chute	N	--	--	N	N	--
EF US CONF KR	East Fork Kaweah River	Mainstem, P	36.47774	-118.83538	5/28/2018	Bedrock Chute	N	--	--	N	N	--

Table A-3. Locations, Quantity, Life Stages, and Sizes of Amphibians and Aquatic Reptiles Observed During Three Visual Encounter Surveys

Species	Common Name	Lifestage, Number	Latitude	Longitude	Date	Study/ Reference Reaches	River	Stream Type	Habitat	Notes
<i>Hyla regilla</i>	Pacific treefrog	Adult	36.464053	-118.91268	9/13/2018	North Fork Kaweah River	North Fork Kaweah River	Permanent Tributary	Sedges On Bank	--
<i>Hyla regilla</i>	Pacific treefrog	Metamorphs, 3 On Bank	36.464284	-118.91265	9/13/2018	North Fork Kaweah River	North Fork Kaweah River	Permanent Tributary	Sedges On Bank	--
<i>Hyla regilla</i>	Pacific treefrog	Adults	36.482486	-118.83778	5/25/2018	KR US CONF EF	Kaweah River	Mainstem	Off Channel Wet Area, Bedrock Outcrop	Flume is leaking and making wet spot at base of rock face
<i>Hyla regilla</i>	Pacific treefrog	Tadpoles Stage 39	36.476638	-118.83380	5/28/2018	EF US CONF KR - Trib	East Fork Kaweah River	Ephemeral Tributary	Remnant Pools In Ephemeral Tributary	--
<i>Hyla regilla</i>	Pacific treefrog	Adult	36.477696	-118.83580	9/11/2018	EF US CONF KR	East Fork Kaweah River	Mainstem	Channel Margin	--
<i>Hyla regilla</i>	Pacific treefrog	Adult	36.515916	-118.80237	4/23/2018	Marble Fork and Middle Fork Kaweah Rivers (Qualitative)	Marble Fork Kaweah River near Potwisha	Permanent Tributaries	Sidechannel And Trib Of Marble Fk	--
<i>Hyla regilla</i>	Pacific treefrog	Eggmasses	36.458273	-118.87216	4/24/2018	KR US PH2 - Trib	Salt Creek	Ephemeral Tributary	Pool	Willow roots with clutches, pool 80 cm deep
<i>Hyla regilla</i>	Pacific treefrog	Eggmasses	36.459246	-118.87198	4/24/2018	KR US PH2 - Trib	Salt Creek	Ephemeral Tributary	Step Pools	--
<i>Hyla regilla</i>	Pacific treefrog	Tadpoles	36.478338	-118.84443	5/26/2018	KR US PH1	Kaweah River	Mainstem	Scour Pool In Bedrock	Depression in rock 1.5 m diameter, tadpoles all recently hatched
<i>Hyla regilla</i>	Pacific treefrog	Tadpoles, Less Than Gosner 26	36.471245	-118.86041	5/26/2018	KR US PH1	Kaweah River	Mainstem	Isolated Side Pool	--
<i>Hyla regilla</i>	Pacific treefrog	Adult	36.477785	-118.84782	4/24/2018	KR US PH1 - Trib	Unnamed Tributary on Doos property	Ephemeral Tributary	Shallow Glide	--
<i>Hyla regilla</i>	Pacific treefrog	Adult	36.479619	-118.84686	4/24/2018	KR US PH1 - Trib	Unnamed Tributary on Doos property	Ephemeral Tributary	Glide Margin	--
<i>Hyla regilla</i>	Pacific treefrog	Tadpoles	36.462930	-118.87211	5/26/2018	KR US PH2	Kaweah River	Mainstem	Stranded Side Pool	--
<i>Hyla regilla</i>	Pacific treefrog	Tadpoles, 200 +	36.488486	-118.82536	5/27/2018	KR US PH3	Kaweah River	Mainstem	Bedrock Scour Hole	Pool 3 x 5 m, 2 m deep water in scour hole, water temp = 17 C
<i>Lithobates catesbeianus</i>	American bullfrog	Adults, 2	36.461865	-118.88194	5/27/2018	KR DS PH2	Kaweah River	Mainstem	Margin Of Run	Bullfrogs were 60 -65 mm body length
<i>Lithobates catesbeianus</i>	American bullfrog	Tadpoles, 200-300	36.460920	-118.88070	9/14/2018	KR DS PH2	Kaweah River	Mainstem	Midchannel Island	--
<i>Lithobates catesbeianus</i>	American bullfrog	Tadpoles, 1/m ² Along Margins	36.461251	-118.88164	9/14/2018	KR DS PH2	Kaweah River	Mainstem	Channel Margin	--
<i>Lithobates catesbeianus</i>	American bullfrog	Tadpoles, Stage 40, Total Length 140 mm	36.460890	-118.88548	9/14/2018	KR DS PH2	Kaweah River	Mainstem	Margin Of Run	--
<i>Lithobates catesbeianus</i>	American bullfrog	Tadpoles, 10 All ca. 20 mm Body Length	36.460735	-118.88652	9/14/2018	KR DS PH2	Kaweah River	Mainstem	Margin Of Run	--
<i>Lithobates catesbeianus</i>	American bullfrog	Tadpoles, 2 @40 mm Body Length, 1 @37 mm, Stage 39	36.461453	-118.88323	9/14/2018	KR DS PH2	Kaweah River	Mainstem	Margin Of Run	--

Species	Common Name	Lifestage, Number	Latitude	Longitude	Date	Study/ Reference Reaches	River	Stream Type	Habitat	Notes
<i>Lithobates catesbeianus</i>	American bullfrog	Tadpoles, Large 2Nd Year	36.466080	-118.91149	9/13/2018	North Fork Kaweah River	North Fork Kaweah River	Permanent Tributary	Margin Of Run	Epiphytized Cladophora on rocks
<i>Lithobates catesbeianus</i>	American bullfrog	Tadpoles, Large 2Nd Year	36.464928	-118.91223	9/13/2018	North Fork Kaweah River	North Fork Kaweah River	Permanent Tributary	Pool	Largemouth bass also in pool
<i>Lithobates catesbeianus</i>	American bullfrog	Tadpoles, 5 First Yr	36.464402	-118.91247	9/13/2018	North Fork Kaweah River	North Fork Kaweah River	Permanent Tributary	Pool	--
<i>Lithobates catesbeianus</i>	American bullfrog	Tadpole	36.463820	-118.91272	9/13/2018	North Fork Kaweah River	North Fork Kaweah River	Permanent Tributary	Pool	--
<i>Lithobates catesbeianus</i>	American bullfrog	Tadpole, 5	36.463352	-118.91258	9/13/2018	North Fork Kaweah River	North Fork Kaweah River	Permanent Tributary	Pool	--
<i>Lithobates catesbeianus</i>	American bullfrog	Adult	36.478821	-118.84416	5/26/2018	KR US PH1	Kaweah River	Mainstem	Stagnant Side Pool	Very tannic and iron precipitating bacteria
<i>Lithobates catesbeianus</i>	American bullfrog	2 Adults	36.475496	-118.85217	5/26/2018	KR US PH1	Kaweah River	Mainstem	Pool 80 X 8 M	Willows and alders along margins; flow study marker says "benchmark 6"
<i>Lithobates catesbeianus</i>	American bullfrog	Tadpoles, Body 18-22 mm, Total 46-50 mm; Stage 26	36.476775	-118.84936	9/13/2018	KR US PH1	Kaweah River	Mainstem	Sidepool	100's of tadpoles feeding on epineustic film, bottom sandy, abundant macrophytes
<i>Lithobates catesbeianus</i>	American bullfrog	Tadpoles, Body 18-22 mm, Total 46-50 mm; Stage 26	36.476774	-118.84959	9/13/2018	KR US PH1	Kaweah River	Mainstem	Sidepool	Density 50 -100 / m ²
<i>Lithobates catesbeianus</i>	American bullfrog	Tadpoles, Body 18-22 mm, Total 46-50 mm; Stage 26	36.475439	-118.85166	9/13/2018	KR US PH1	Kaweah River	Mainstem	Sidepool	--
<i>Lithobates catesbeianus</i>	American bullfrog	Tadpoles, Body 18-22 mm, Total 46-50 mm; Stage 26	36.475116	-118.85218	9/13/2018	KR US PH1	Kaweah River	Mainstem	Sidepool	--
<i>Lithobates catesbeianus</i>	American bullfrog	Tadpoles, Body 26 mm, Total 58-62 mm; Stage 26	36.475012	-118.85274	9/13/2018	KR US PH1	Kaweah River	Mainstem	Sidepool	--
<i>Lithobates catesbeianus</i>	American bullfrog	Adult	36.474945	-118.85316	9/13/2018	KR US PH1	Kaweah River	Mainstem	Sidechannel	--
<i>Lithobates catesbeianus</i>	American bullfrog	Juvenile	36.477190	-118.84792	4/24/2018	KR US PH1 - Trib	Unnamed Tributary on Doos Property	Ephemeral Tributary	Pool	--
<i>Lithobates catesbeianus</i>	American bullfrog	Adult, 62 mm Sul	36.479275	-118.84705	4/24/2018	KR US PH1 - Trib	Unnamed Tributary on Doos Property	Ephemeral Tributary	Pool	Sunny, one of few pools with open canopy that increases suitability for FYLF
<i>Lithobates catesbeianus</i>	American bullfrog	2 Adults	36.479383	-118.84682	4/24/2018	KR US PH1 - Trib	Unnamed Tributary on Doos Property	Ephemeral Tributary	Pool	Sunny, one of few pools with open canopy that increases suitability for FYLF
<i>Lithobates catesbeianus</i>	American bullfrog	Adult	36.479460	-118.84686	4/24/2018	KR US PH1 - Trib	Unnamed Tributary on Doos Property	Ephemeral Tributary	Pool	--
<i>Lithobates catesbeianus</i>	American bullfrog	Tadpoles, All <20 mm Body Length	36.459962	-118.87173	9/13/2018	KR US PH2	Kaweah River	Mainstem	Side Pool	Stagnant side channel, 100's of first year bullfrog tadpoles, < 20 mm body length
<i>Taricha sierrae</i>	Sierra newt	Larvae, 3	36.451514	-118.78981	9/12/2018	EF DS K1 DIV	East Fork Kaweah River	Mainstem	Margin Of Pool	Larvae in willow roots

Species	Common Name	Lifestage, Number	Latitude	Longitude	Date	Study/ Reference Reaches	River	Stream Type	Habitat	Notes
<i>Taricha sierrae</i>	Sierra newt	Larvae	36.450591	-118.78808	9/12/2018	EF DS K1 DIV	East Fork Kaweah River	Mainstem	Pool	Shallow pool sandy, bedrock cliffs on sides, difficult for a turtle to get out of water
<i>Taricha sierrae</i>	Sierra newt	Adult Females, 6 Eggmasses, Juveniles, Larvae	36.454130	-118.78896	5/24/2018	EF DS K1 DIV - Trib	Unnamed Tributary to East Fork Kaweah River	Ephemeral Tributary	Step Pools / Cascades	--
<i>Taricha sierrae</i>	Sierra newt	Adult	36.453872	-118.78985	5/24/2018	EF DS K1 DIV - Trib	Unnamed Tributary to East Fork Kaweah River	Ephemeral Tributary	Cascade Pools	--
<i>Taricha sierrae</i>	Sierra newt	Gravid Female	36.453165	-118.78981	5/24/2018	EF DS K1 DIV - Trib	Unnamed Tributary to East Fork Kaweah River	Ephemeral Tributary	Cascade Pools	--
<i>Taricha sierrae</i>	Sierra newt	Eggmasses, 3 Clutches	36.448661	-118.77279	5/24/2018	EF US K1 DIV - Trib	Unnamed Tributary to East Fork Kaweah River	Ephemeral Tributary	Cascade Pools	--
<i>Taricha sierrae</i>	Sierra newt	Eggmasses, 9 Clutches	36.449117	-118.77252	5/24/2018	EF US K1 DIV - Trib	Unnamed Tributary to East Fork Kaweah River	Ephemeral Tributary	Bedrock Step Pool	Pools approximately 3.5 m in diameter, 40 cm deep
<i>Taricha sierrae</i>	Sierra newt	Eggmasses, 28 Clutches	36.449308	-118.77248	5/24/2018	EF US K1 DIV - Trib	Unnamed Tributary to East Fork Kaweah River	Ephemeral Tributary	Bedrock Step Pools	Pools approximately 3.5 m in diameter, 40 cm deep
<i>Taricha sierrae</i>	Sierra newt	Eggmasses, 4 Groups Of Clutches Starting To Strand	36.449508	-118.77224	5/24/2018	EF US K1 DIV - Trib	Unnamed Tributary to East Fork Kaweah River	Ephemeral Tributary	Shallow Pool	--
<i>Taricha sierrae</i>	Sierra newt	2 Adults	36.490431	-118.82295	4/23/2018	KR US PH3 - Trib	Unnamed Tributary near Ash Mountain Visitor Center	Ephemeral Tributary	Pools	Near confluence with Salt Creek
<i>Thamnophis couchii</i>	Gartersnake	Adult	36.464402	-118.91247	9/13/2018	North Fork Kaweah River	North Fork Kaweah River	Permanent Tributary	Pool	--
<i>Thamnophis couchii</i>	Gartersnake	Adult, 55 cm Total Length	36.451083	-118.79022	9/12/2018	EF DS K1 DIV	East Fork Kaweah River	Mainstem	Margin Of Pool	Pool with Spirogyra algae and sculpins
<i>Thamnophis couchii</i>	Gartersnake	Adult, 40 cm Total Length	36.450658	-118.79021	9/12/2018	EF DS K1 DIV	East Fork Kaweah River	Mainstem	Margin Of Pool	--
<i>Thamnophis couchii</i>	Gartersnake	Juvenile	36.454789	-118.78821	5/24/2018	EF DS K1 DIV - Trib	Unnamed Tributary to East Fork Kaweah River	Ephemeral Tributary	Bedrock Slit, Pool 2 M Wide By 5 M Long	Turn around point, on eastern branch of the trib
<i>Thamnophis couchii</i>	Gartersnake	Adult	36.452147	-118.79012	5/24/2018	EF DS K1 DIV - Trib	Unnamed Tributary to East Fork Kaweah River	Ephemeral Tributary	Bedrock Pool	Zygnematales in pool where sunny
<i>Thamnophis couchii</i>	Gartersnake	2 Adults, 45 And 70 cm Total Length	36.476191	-118.83466	5/28/2018	EF US CONF KR	East Fork Kaweah River	Mainstem	Bedrock Pool	--
<i>Thamnophis couchii</i>	Gartersnake	Adult, 30 cm Total Length, but Skinny	36.474545	-118.83405	9/11/2018	EF US CONF KR	East Fork Kaweah River	Mainstem	Pool	--

This Page Intentionally Left Blank

Table A-4. Locations of Native and Non-Native Fauna Which Have Similar Physical Habitat Requirements as FYLF and May Indicate Site Suitability

Species	Common Name	Life Stage, Number	Latitude	Longitude	Date	Study Reach	River	Flow Status P=Project, R=Ref	Meso Habitat	Notes
<i>Margaritifera falcata</i>	Western pearlshell mussel	Adult	36.4766020	-118.8462960	4/24/2018	KR US PH1	Kaweah River	P	Pool	Shell: 85 x 45 mm; Sandy area near patch of FYLF habitat at pool tail out
<i>Margaritifera falcata</i>	Western pearlshell mussel	Shell	36.4791340	-118.8377860	5/28/2018	EF US CONF KR	East Fork Kaweah River	P	Islands And Side Channel River Right	--
<i>Margaritifera falcata</i>	Western pearlshell mussel	Adult	36.4791080	-118.8381080	9/11/2018	EF US CONF KR	East Fork Kaweah River	P	Pool	--
<i>Margaritifera falcata</i>	Western pearlshell mussel	Adult, 4	36.4789180	-118.8373010	9/11/2018	EF US CONF KR	East Fork Kaweah River	P	Pool	Shell lengths: 104.8, 103.4, 61, 58 mm; also found some half eaten
<i>Margaritifera falcata</i>	Western pearlshell mussel	Adult	36.4777950	-118.8359820	9/11/2018	EF US CONF KR	East Fork Kaweah River	P	Pool	--
<i>Margaritifera falcata</i>	Western pearlshell mussel	Adult, 3	36.4751210	-118.8340330	9/11/2018	EF US CONF KR	East Fork Kaweah River	P	Pool Tail Out	Shell lengths: 81.2, 84.5, 59.0 mm, 2 partially eaten perhaps by otter
<i>Corbicula</i>	Asian clam	Adult	36.4635500	-118.9126410	9/13/2018	North Fork Kaweah River	North Fork Kaweah River	R	Shallow Pool	--
<i>Corbicula</i>	Asian clam	Adult	36.4633520	-118.9125850	9/13/2018	North Fork Kaweah River	North Fork Kaweah River	R	Pool	--
<i>Corbicula</i>	Asian clam	Adult	36.4584550	-118.8887100	9/14/2018	KR DS PH2	Kaweah River	P	Run	--
<i>Corbicula</i>	Asian clam	Adult	36.4586600	-118.8890110	9/14/2018	KR DS PH2	Kaweah River	P	Side Channel	--
<i>Diadophis punctatus</i>	Ringneck snake	Adult	36.4485700	-118.7725920	5/24/2018	EF US K1 DIV trib	East Fork Kaweah River	R	Bedrock Outcrop Next To Creek	--
<i>Pacifastacus leniusculus</i>	Signal crayfish	Adult	36.4631760	-118.9125230	9/13/2018	North Fork Kaweah River	North Fork Kaweah River	R	Edgewater	--

This Page Intentionally Left Blank

Appendix B

Habitat Photographs

This Page Intentionally Left Blank



PHOTO B-1. Amphibian habitat upstream of Kaweah No. 3 Powerhouse consists of depositional zones at pool tail outs (top, arrows), bedrock potholes used by treefrogs (*Hyla regilla*) to breed, but which dry by late summer (lower left and right), and side channels which remain wet (lower right).



PHOTO B-2. Kaweah River upstream of confluence with East Fork Kaweah River. Arrow (left) indicates leak from flume creating off-channel habitat for amphibians occupied by Pacific treefrogs (*Hyla regilla*), while in channel oviposition habitat for frogs is limited to small pockets of low velocity downstream of large boulders (right top and bottom). Surveyor is using a view tube to search for FYLF (*Rana boylei*) clutches.



PHOTO B-3. Confluence (left) of an ephemeral tributary (middle) with the Kaweah River upstream of Kaweah No. 1 Powerhouse with suitable habitat for FYLF (*Rana boylei*) but occupied by juvenile Bullfrogs (right, *Lithobates catesbeianus*).



PHOTO B-4. In the Kaweah River upstream of Kaweah No. 2 Powerhouse occupied amphibian habitat includes side pools (top left) where 100's of first year Bullfrog (*Lithobates catebeianus*) tadpoles (body length <20 mm) occurred (top right) and channel margins with second year bullfrog tadpoles. Potential breeding habitat for FYLF (*Rana boylei*) exists in midchannel islands (bottom).



PHOTO B-5. In the Kaweah River downstream of Kaweah No. 2 Powerhouse, margins of side channels where boulders and cobbles are covered with heavily epiphytized *Cladophora*, could be good habitat for FYLF (*Rana boylei*) tadpoles. Instead the reach was occupied by large bullfrog tadpoles, some with non-native parasitic copepods (*Lernaea cyprinacea*), note blue arrow.

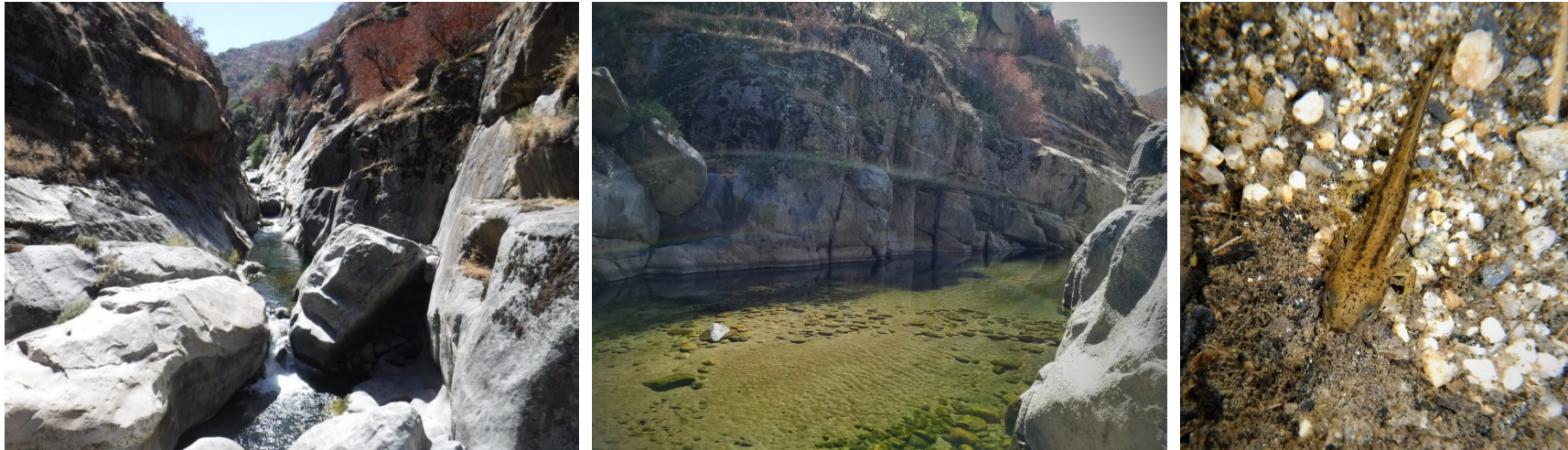

PHOTO B-6. The narrow bedrock dominated channel upstream of Kaweah No. 1 Diversion in the East Fork Kaweah River offered little habitat for amphibians, but in one relatively wide pool newt larvae were found taking refuge under cobbles and boulders. Larva of *Taricha sierrae* (right) in Sept. 2018 (total length = 58 mm).



PHOTO B-7. East Fork Kaweah River downstream of Kaweah No. 1 Diversion is dominated by bedrock cascades, but at low flow has pockets of cobble and boulder habitat (top left) that might be suitable for FYLF as indicated by the presence of aquatic garter snakes, *Thamnophis couchii* (top right). Tributaries where eggs and larvae of treefrogs and newts were found in spring (lower left) were completely dry by September (lower right). Tributary drying may be hastened by diversions (upper left).

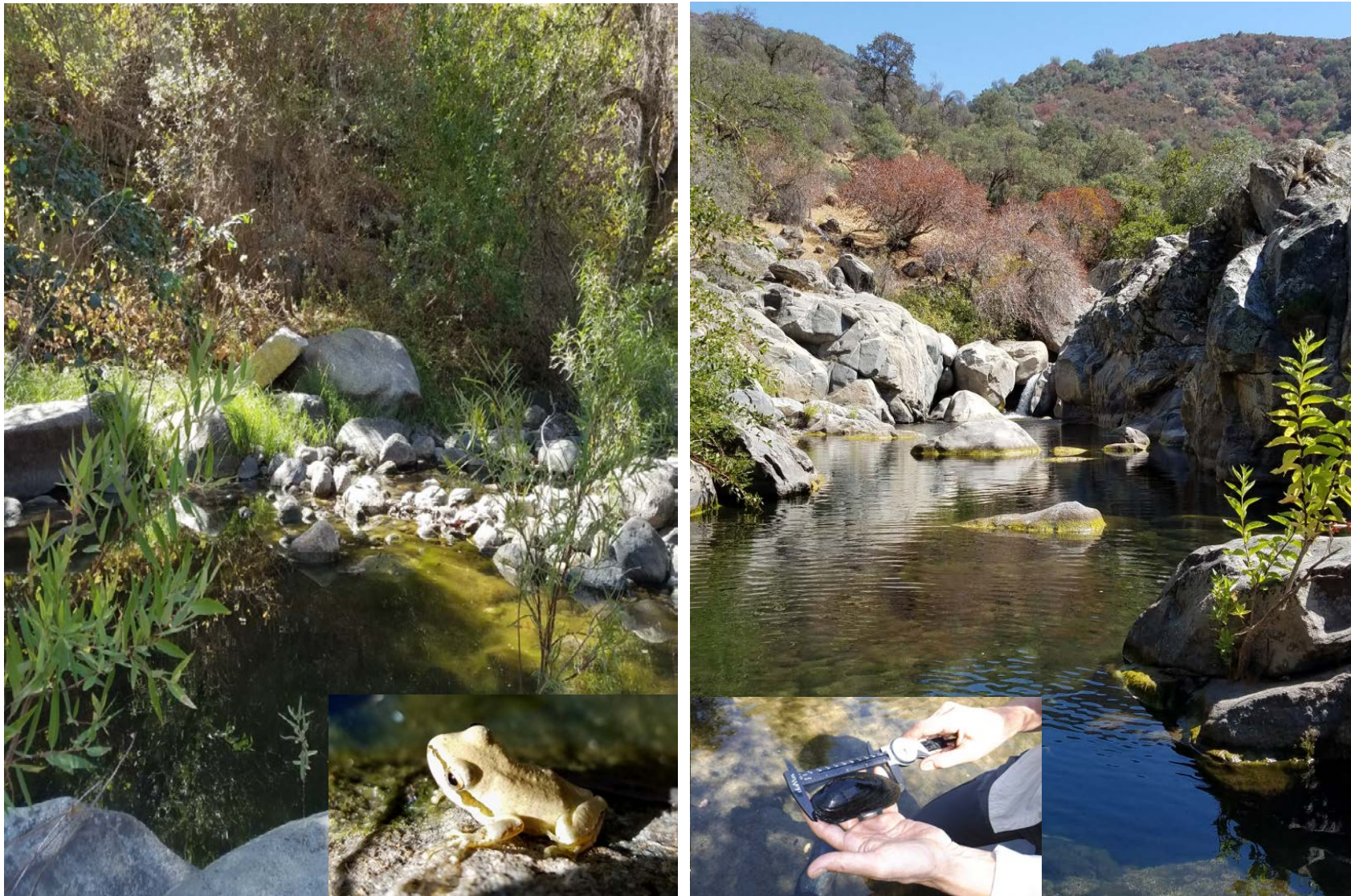

PHOTO B-8. East Fork Kaweah River upstream of confluence with Kaweah River. Habitats suitable for FYLF (*Rana boylei*) include: side pool with Pacific treefrogs (*Hyla regilla*, left and inset) and main channel pool (right and inset) where Western Pearlshell Mussels (*Margaritifera falcata*) occurred near channel margin.

Kaweah Project, FERC Project No. 298

AQ 8 – Fish Passage Final Technical Study Report

December 2019



Southern California Edison Company
Regulatory Support Services
1515 Walnut Grove Avenue, Rosemead, CA 91770

Table of Contents

1	Introduction	1
2	Study Objectives	1
3	Extent of Study Area.....	1
4	Study Approach	1
5	Study Results	3
5.1	Fish Passage Barriers in Kaweah River.....	3
5.2	Fish Passage Barriers in East Fork Kaweah River	3
5.3	Potential Barriers Requiring Hydrodynamic Modeling.....	4
6	Literature Cited.....	4

List of Tables

Table AQ 8-1.	Potential Fish Passage Barriers.....	1
---------------	--------------------------------------	---

List of Figures

Figure AQ 8-1.	Summary of Parameters Measured at Each Potential Barrier during 2018 Field Visits.....	1
Figure AQ 8-2.	Fish Swimming Speed vs. Time.....	2
Figure AQ 8-3.	Fish Vertical and Horizontal Leaping Ability.	2
Figure AQ 8-4.	Chute Water Velocity vs. Fish Swimming Distance.	3

List of Maps

Map AQ 8-1.	Kaweah Project Fish Passage Barrier Locations and Category.....	1
-------------	---	---

List of Appendices

Appendix A	Quantitative Barrier Assessment Data Sheet
Appendix B	Quantitative Fish Barrier Evaluation Approach
Appendix C	Detailed Fish Passage Barrier Descriptions
Appendix D	River Gradient Plots

List of Acronyms

°C	degrees Celsius
FERC	Federal Energy Regulatory Commission
FL	fork length
ft	feet
lengths/sec	lengths per second
mm	millimeter
Project	Kaweah Project
PSP	Proposed Study Plan
RM	River Mile
RSP	Revised Study Plan
SCE	Southern California Edison Company
SNP	Sequoia National Park
TSP	Technical Study Plan
TSR	Technical Study Report
USFWS	U.S. Department of Fish and Wildlife Service

1 INTRODUCTION

This Technical Study Report (TSR) describes the data and findings developed by Southern California Edison Company (SCE) in association with implementation of the AQ 8 – Fish Passage Technical Study Plan (AQ 8 – TSP) for the Kaweah Project (Project). The AQ 8 – TSP was included in SCE’s Revised Study Plan (RSP)¹ (SCE 2017a) and was approved by the Federal Energy Regulatory Commission (FERC) on October 24, 2017 as part of its Study Plan Determination for the Project (FERC 2017). Specifically, this report provides a description of the methods and results of AQ 8 – TSP completed in 2018.

2 STUDY OBJECTIVES

The AQ 8 – TSP included two study objectives, as follows:

- Document the location, nature, and characteristics of fish barriers in bypass river reaches².
- Identify Project facilities and operations (e.g., diversion structures, instream flow releases) that may affect fish passage.

3 EXTENT OF STUDY AREA

The study area includes the bypass river reaches and Project diversion dams (Map AQ 8-1).

4 STUDY APPROACH

- Identification and classification potential fish passage barriers in bypass river reaches was accomplished using the following approach:
 - The AQ 1 – Instream Flow TSP mesohabitat mapping data were used to identify the location and nature (natural or Project-related) of potential barriers (e.g., natural falls, tributary junctions, road crossings, shallow riffles, and diversion or dam structures) in the bypass river reaches.
 - Potential barriers were revisited after the mesohabitat mapping study and each of the potential barriers were classified into the falls, chute, and cascade types defined by Powers and Orsborn (1985) or as critical riffles (Thompson 1972).
 - Because much of the East Fork Kaweah River is too narrow and steep to be accessible, we were only able to visit the first potential natural barrier on the downstream end of the river (i.e., near the Kaweah River confluence) and a potential natural barrier on the upstream end (i.e., near the bridge crossing and Kaweah No. 1 Diversion). Other potential natural barriers on the East Fork Kaweah were identified from aerial photographs.
 - Fish passage assessment data were collected at each of the barriers visited in the field. The data included fall height, plunge pool depth, water velocity, photographs, and field biologist observations. The specific measurements are shown in Figure AQ 8-1. An example of the field data sheet that was used is shown in Appendix A. In addition, the barriers were also assessed qualitatively for fish passage by the field biologist at flows not present during the field visit

¹ SCE filed a Proposed Study Plan (PSP) on May 24, 2017 (SCE 2017b). Three comments were filed on the PSP, however, they did not result in revisions to any of the study plans. Therefore, SCE filed a Revised Study Plan (RSP) on September 19, 2017, which stated that the PSP, without revision, constituted its RSP. The FERC subsequently issued a Study Plan Determination on October 24, 2017 approving all study plans for the Kaweah Project.

² A bypass reach is a segment of a river downstream of a diversion facility where Project operations result in the diversion of a portion of the water from that reach. Typically the diverted water re-enters the river through a powerhouse at the downstream end of the bypass reach.

(e.g., high flows) by visually determining if there were obvious passage routes through or around the barrier that would be present at a different flow that would allow passage.

- Fish passage at the potential Project-related and natural fish barriers was evaluated typically during the low-flow period (some sites were visited at higher flows) using the swimming and leaping capabilities of trout (particularly rainbow trout) and minnows/suckers (hardhead, Sacramento pikeminnow, Sacramento sucker). Barriers were classified as impassable if at both low and high flow it was determined that fish could not traverse the barrier and partial if at some flow (e.g., high flow) a pathway was likely to exist that would provide passage. The general upstream fish passage assessment methodology outlined in Powers and Orsborn (1985) and Thompson (1972) was used to evaluate passage at potential vertical barriers (falls), high velocity chutes, and/or critical riffles based on field measurements of the barriers. Appendix B provides a detailed discussion of the analysis approach and methods and the literature sources of the quantitative fish performance data.
- A range of swimming velocity was used for the trout (high and low swimming estimates). Minnow and sucker swimming capability was set at the lower end of the trout swimming range. Figure AQ 8-2 shows the assumed swimming capabilities of fish. Burst swimming velocity was used to determine the leaping ability of fish (i.e., their ability to navigate vertical barriers). Prolonged and sustained swimming capability was used to determine the ability of fish to navigate high velocity water in chutes and riffles (Powers and Orsborn 1985). Burst swimming (less than 0.1 minute) was assumed to range between 8 and 12 body lengths/second (lengths/sec) for salmonids (trout) (Beamish 1978; Reiser and Peacock 1985; Videler 1993). Burst swimming for cyprinids (minnows and catostomids (suckers) was set on the lower end of the trout range (8 body lengths/sec). The sixty-minute sustained swimming velocity was assumed to be between 2 and 4 body lengths/sec for trout (Brett and Glass 1973; Beamish 1978; Reiser and Peacock 1985) and approximately 2 body lengths/sec for minnows/suckers³ (Myrick and Cech 2000; Berry and Pimentel 1985). Prolonged swimming (0.1–60 minutes) was assumed to vary between burst and sustained swimming speed logarithmically (Videler 1993).
- Barriers were analyzed for passage by a 12-inch (305 mm [millimeter]) trout or minnow (e.g., hardhead, Sacramento pikeminnow) at a typical late Spring / early Summer water temperature of 15°Celsius (°C) (e.g., temperature when spawning/post-spawning movement would potentially occur). The 12-inch (305 mm) fish size was used for the analysis to represent a large trout in the system. During the fish population sampling (AQ 2 – Fish Population Study), the largest trout measured was 8.5 inches (216 mm fork length [FL]) and the largest trout observed (snorkeling) was in the 10 to 12-inch size class. For fish in the approximately 12-inch and less size, empirical fish leaping data from the literature indicate that smaller fish (e.g., 6 inches) can leap as high as larger fish (e.g., 8+ inches) (Kondratieff and Myrick 2006). This is partly because the maximum swimming speed per body length is higher for smaller fish (e.g., <12 inches) than it is for larger fish (e.g., ≥12 inches) (see compilation of data in Kondratieff and Myrick 2006). As a result, we used the leaping and swimming ability of a 12-inch fish as reasonable representation for the passage capabilities of various sized fish in the Project area. The same fish size was used for hardhead, Sacramento pikeminnow, and Sacramento sucker.
- The vertical and horizontal leaping relationships based the maximum burst swimming velocity that was used in the analysis are shown in Figure AQ 8-3. The leaping ability was used to assess passage at falls. Burst and prolonged swimming velocity versus duration relationships were used to evaluate water velocity versus fish swimming distance for the chute passage analysis

³ Critical swimming velocity data (a laboratory measure of prolonged swimming capacity) for hardhead, Sacramento pikeminnow, Colorado pikeminnow, and Sacramento sucker (Myrick and Cech 2000; Berry and Pimentel 1985) were compared to data for rainbow trout (Beamish 1978; Hawkins and Quinn 1996; Jain et al. 1997). Minnow/sucker species swimming velocities were comparable to the lower range observed for trout (typically about 2 body lengths/sec).

(Figure AQ 8-4). Water depth in the plunge pool, crest of a falls, or in a chute was also used to assess falls and chute passage. The details are provided in Appendix B.

- Historical data on potential fish barriers (SCE 2007) collected within the Sequoia National Park (SNP), but outside the relicensing study area were included in this report to provide context to the location and frequency of natural barriers in the Kaweah River watershed. The historical data extends from the SNP boundary near RM 9.5 (Map AQ 8-1) upstream to approximately 1,500 feet (ft) above the Marble Fork Diversion and Middle Fork Diversion within the SNP. Only barriers documented by SCE (2007) that were classified as impassable barriers or high severity barriers were incorporated. We assumed the impassable barriers were impassable and the high severity barriers were assumed in this report as partial barriers. SCE (2007) described them as not passable under low flow conditions and potentially passable with substantial difficulty at higher flows.
- The AQ 8 – Fish Passage Study Plan contemplated that if there were any stream crossings identified that were potential barriers (e.g., culverts), then the stream crossings would be evaluated for fish passage consistent with Flosi, et al. (2010). In addition, if any Project-related barriers were identified, which potentially required hydrodynamics modeling to assess fish passage over a range of flows, this would be completed in collaboration with resource agencies. Only barriers that prevented access to sections of river with important spawning or rearing habitat (as determined in collaboration with the resource agencies) would be considered for modeling.

5 STUDY RESULTS

Map AQ 8-1 shows the barriers identified during the 2018 surveys and barriers that were previously documented upstream of River Mile (RM) 9.5 in the SNP boundary as part of another study (SCE 2007). Pictures and details of barriers surveyed in 2018 are summarized in Table AQ 8-1 and Appendix C.

5.1 Fish Passage Barriers in Kaweah River

In the Kaweah River there were two Project-related barriers identified, including the Kaweah No. 2 Diversion Dam (RM 8.9) and Kaweah No. 2 Diversion Dam Gage Pool Weir (RM 8.8). The Kaweah No. 2 Diversion Dam was identified as an impassable barrier and the Kaweah No. 2 Diversion Dam Gage Pool Weir was identified as a partial barrier to fish passage (Map AQ 8-1; Table AQ 8-1; Appendix C).

Additionally, one partial natural barrier was documented on the Kaweah River below Kaweah No. 2 Powerhouse at RM 3.8 and another impassable natural barrier within the SNP at RM 9.5 approximately 0.6 mile upstream of the Kaweah No. 2 Diversion Dam.

The Kaweah No. 2 Diversion Dam at RM 8.9 precludes upstream fish passage into the river reach from RM 8.9–9.5. Above the impassable natural barrier at RM 9.5, SCE (2007) documented numerous upstream migration partial barriers, one additional impassable barrier in the Kaweah River (below the confluence of the Middle Fork Kaweah River and Marble Fork Kaweah River), and several impassable barriers in the Middle Fork Kaweah and Marble Fork Kaweah rivers upstream of their confluence (natural and manmade).

5.2 Fish Passage Barriers in East Fork Kaweah River

In the East Fork Kaweah River, there were two Project-related barriers, including the Kaweah No. 1 Diversion Dam and Kaweah No. 1 Diversion Dam Gage Pool Weir (Map AQ 8-1; Table AQ 8-1; Appendix C). Both structures create impassable fish barriers at approximately RM 4.7.

Downstream of the Project-related barriers there were two natural barriers that were surveyed – an impassable natural barrier on the East Fork Kaweah River near the confluence at RM 0.2 and an impassable natural barrier at RM 4.4 below the Kaweah River Bridge. Analysis of aerial photographs and

topographic maps of the river stretch between these natural barriers suggest many similar impassable barriers in this section of river, however, ground surveys are unsafe due to steep terrain.

5.3 Potential Barriers Requiring Hydrodynamic Modeling

No stream crossings were identified that created fish passage barriers. No Project-related fish passage barriers were identified where further study (e.g., hydrodynamics modeling) appeared warranted to understand passage over a wide range of flows. The Project-related impassable were large enough to be barriers over a wide range of flows (low to high) (i.e., additional hydrodynamics modeling would not change the conclusion). The natural barrier on the Kaweah River at RM 3.8 (partial barrier) is located below the Project (below Powerhouse No. 2 tailrace); therefore, the Project does not influence flows at this barrier. The lower flows that affect passage at this barrier are a product of natural hydrology in the Kaweah River Watershed.

6 LITERATURE CITED

- Beamish, F.W.H. 1978. Swimming Capacity. In Fish Physiology, vol. 7. (eds. W.S. Hoar and D. Randall), pp. 101-187. Academic Press, New York.
- Berry, C.R., and R. Pimentel. 1985. Swimming Performances of Three Rare Colorado River Fishes. Transactions of the American Fisheries Society 114:397-402.
- Brett, J.R., and N.R. Glass. 1973. Metabolic rates and critical swimming speeds of sockeye salmon (*Oncorhynchus nerka*) in relation to size and temperature. J. Fish. Res. Bd Can. 30, 379-387.
- FERC (Federal Energy Regulatory Commission). 2017. Study Plan Determination for the Kaweah Hydroelectric Project. October 24.
- Flosi, G., S. Downi, J. Hopelain, M. Bird, R. Coey, and B. Collins. 2010. California Salmonid Stream Habitat Restoration Manual Vol. II, Part IX, Fish Passage Evaluation at Stream Crossings. California Department of Fish and Game.
- Hawkins, D.K., and T.P. Quinn. 1996. Critical Swimming Velocity and Associated Morphology of Juvenile Coastal Cutthroat Trout (*Oncorhynchus clarki clarki*), and Steelhead Trout (*Oncorhynchus mykiss*), and their Hybrids. Can. J. Fish. Aquat. Sci. 53:1487-1496.
- Jain, K.E., J.C. Hamilton, and A.P. Farrell. 1997. Use of Ramp Velocity Test to Measure Critical Swimming Speed in Rainbow Trout (*Oncorhynchus mykiss*). Comp. Biochem. Physiol. 117A:441-444.
- Kondratieff, M.C., and C.A. Myrick. 2006. How high can brook trout jump? A laboratory evaluation of brook trout jumping performance. Transaction of the American Fisheries Society. 135: 361-370.
- Myrick, C.A. and J.J. Cech, Jr. 2000. Swimming performances of four California stream fishes: temperature effects. Env. Biol. Fish. 58: 289-295.
- Powers, P.D., and J.F. Orsborn. 1985. Analysis of Barriers to Upstream Migration: An Investigation of the Physical and Biological Conditions Affecting Fish Passage Success at Culverts and Waterfalls. BPA Report No. DOE/BP-36523-1.
- Reiser, D.W., and R.T. Peacock. 1985. A Technique for Assessing Upstream Fish Passage Problems at Small-Scale Hydropower Developments. Symposium on Small Hydropower and Fisheries, May 1-3.
- SCE (Southern California Edison Company). 2007. Aquatic Studies Report for the Kaweah No. 3. Hydroelectric Project. Prepared for Sequoia National Park Ash Mountain Headquarters.
- SCE. 2017a. Kaweah Project, Revised Study Plan. Filed with FERC on September 19.

SCE. 2017b. Kaweah Project, Proposed Study Plan. Filed with FERC on May 24.

Thompson, K. 1972. Determining Stream Flows for Fish Life in Pacific Northwest River Basins
Commission Instream Flow Requirement Workshop, March 15-16, 1972.

Videler, J. J. 1993. Fish Swimming. London, Chapman & Hall.

This Page Intentionally Left Blank

TABLES

This Page Intentionally Left Blank

Table AQ 8-1. Potential Fish Passage Barriers

Barrier ID	River Mile	Barrier Type	Barrier Class	Physical Characteristics					Passable at Low / High Flows		Barrier Limitation
				Height of Barrier (ft)	Horizontal Distance or Length (ft) (Measured or Calculated) ²	Plunge Pool / Chute Depth (ft)	Water Velocity ³ (ft/s)	Flow at Visit (cfs)	Trout	Minnows ⁴	
Kaweah River											
Downstream of National Park Foothills Visitor Center	9.5	Natural	Falls	10.0 ¹	12.0 ¹	-	-	-	NO / NO	NO / NO	Fall Height
Kaweah No. 2 Diversion Dam	8.9	Project	Falls	9.2	16.0	5.0	2.2	338	NO / NO	NO / NO	Fall Height
Kaweah No. 2 Diversion Dam Gage Pool Weir	8.8	Project	Falls	1.0	3.0	5.2	2.2	315	NO ⁵ / YES	NO ⁵ / YES	Fall Height
Downstream of Kaweah No. 2 Powerhouse	3.8	Natural	Falls	1.8	20.0	2.3	0.6	169	NO / YES	NO / YES	Fall Height
East Fork Kaweah River											
Kaweah No. 1 Diversion Dam	4.7	Project	Falls	11.5	15.0	8.0	2.5	188	NO / NO	NO / NO	Fall Height
Kaweah No. 1 Diversion Dam Gage Pool Weir	4.7	Project	Falls/Chute	7.2	11.2 / 17.0	2.5/0.5	3 / >12	122	NO / NO	NO / NO	Fall Height, Chute Velocity, and Length
East Fork Kaweah Downstream of Kaweah River Bridge	4.4	Natural	Falls	9.0	20.0	6.0	4.0	195	NO / NO	NO / NO	Fall Height
East Fork Kaweah above Confluence with Kaweah River	0.2	Natural	Falls/Chute	5.7/9.7	15.0 / 35.8	4.0/0.5	3.8 / 12.2	47	NO / NO	NO / NO	Fall Height, Chute Velocity, and Length

¹ Measurement estimated from online kayaker video.

² Horizontal leap distance required to clear falls and/or swimming length of chutes.

³ Velocity at crest of falls / Velocity in chute.

⁴ "Minnows" include hardhead, Sacramento pikeminnow, and Sacramento sucker.

⁵ Passable at measured flow, but not at low flow.

This Page Intentionally Left Blank

FIGURES

This Page Intentionally Left Blank

Fish Passage Parameters Measured (Abbreviations Shown on Schematics ¹ Below)			
Falls	Chutes	Cascades	Critical Riffles
Width of channel/water at top of crest	Width of water at crest and in chute	Also measure the following for each chute/ fall	Width of riffle
Water depth at crest (dWc)	Water depth at crest (dWc)	Resting pool width, length, and depth if resting pools are present.	Depth across riffle
Water velocity at crest (VWc)	Water velocity at crest (VWc)	Air entrainment %	Velocity across riffle
Angle of water at crest ($\pm \theta Wc$)	Angle of water at crest ($\pm \theta Wc$)	Turbulence (passable or not)	
Fall height (FH)	Chute height (H)		
Depth of plunge pool (dpp)	Depth of water in chute (dW)		
Depth of plunging water (dp)	Velocity of water in chute (VWs)		
Distance from crest to plunge (Xp)	Length of chute slope (LS)		
Distance from plunge to standing wave (XSW)	Slope of chute passage area (Sp)		
	Depth of plunge pool (dpp)		

¹ Powers, P.D. and J.F. Orsborn. 1985. Analysis of Barriers to Upstream Migration: An Investigation of the Physical and Biological Conditions Affecting Fish Passage Success at Culverts and Waterfalls. BPA Report No. DOE/BP-36523-1.

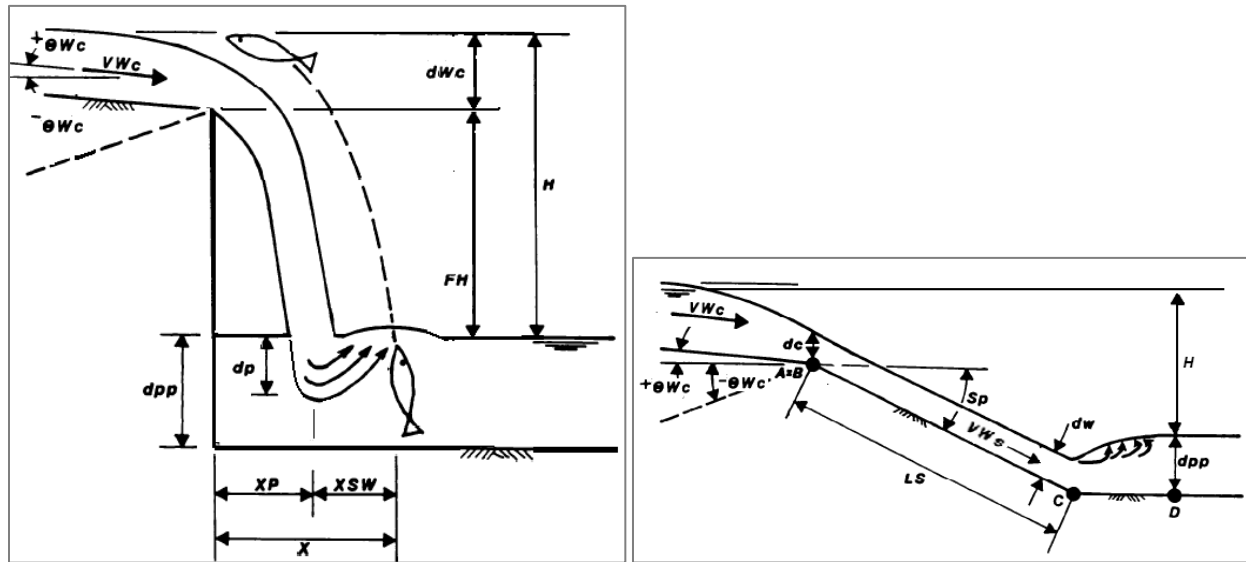

Fall Measurements

Chute Measurements

Figure AQ 8-1. Summary of Parameters Measured at Each Potential Barrier during 2018 Field Visits.

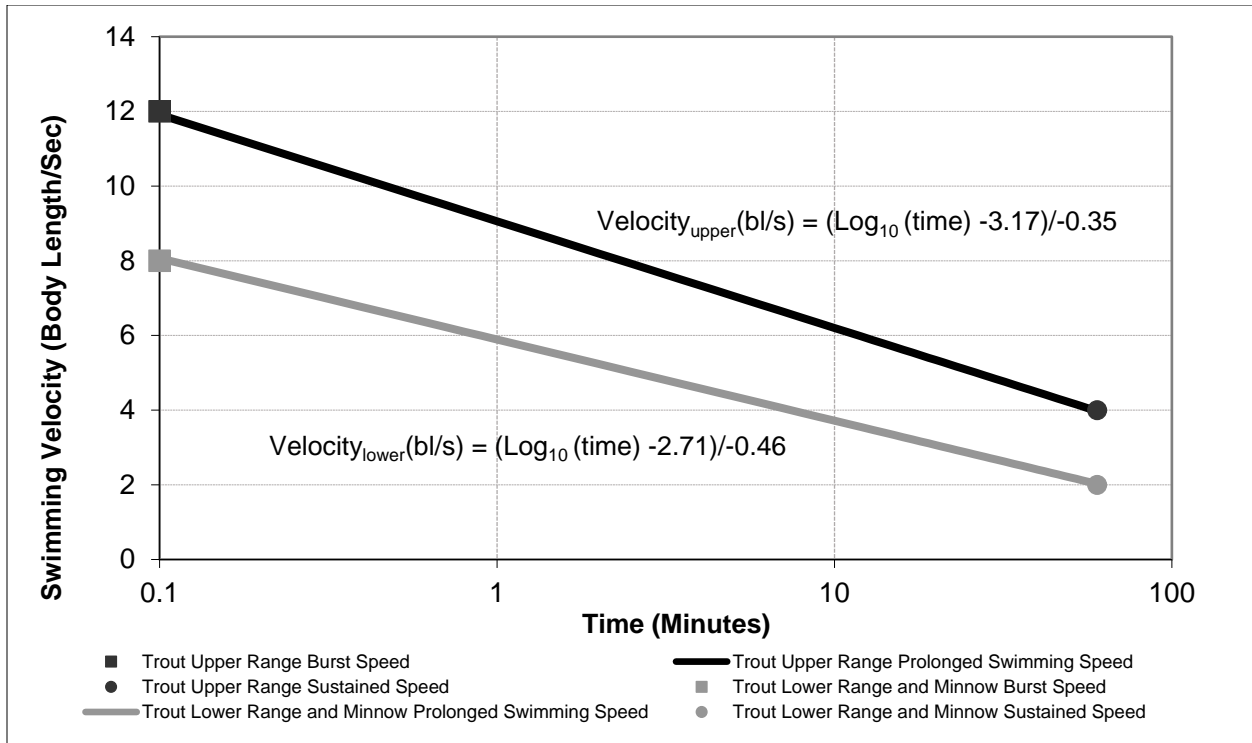

Figure AQ 8-2. Fish Swimming Speed vs. Time.

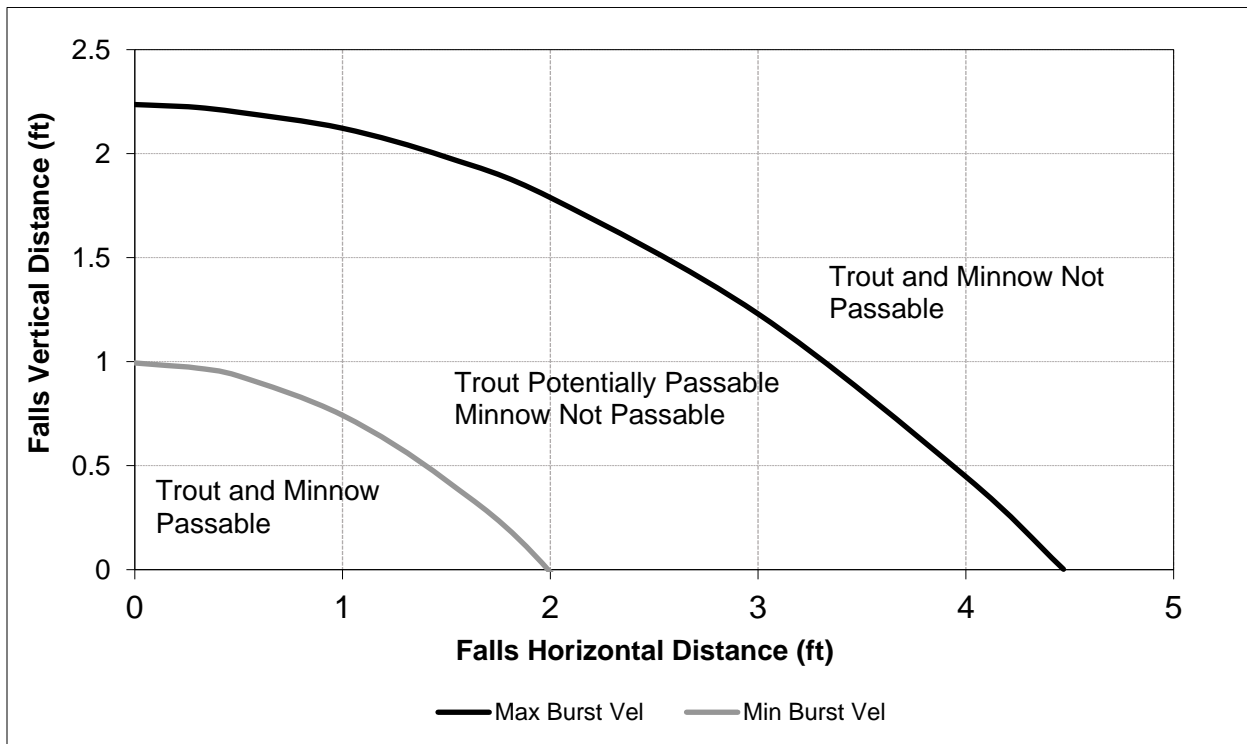

Figure AQ 8-3. Fish Vertical and Horizontal Leaping Ability.

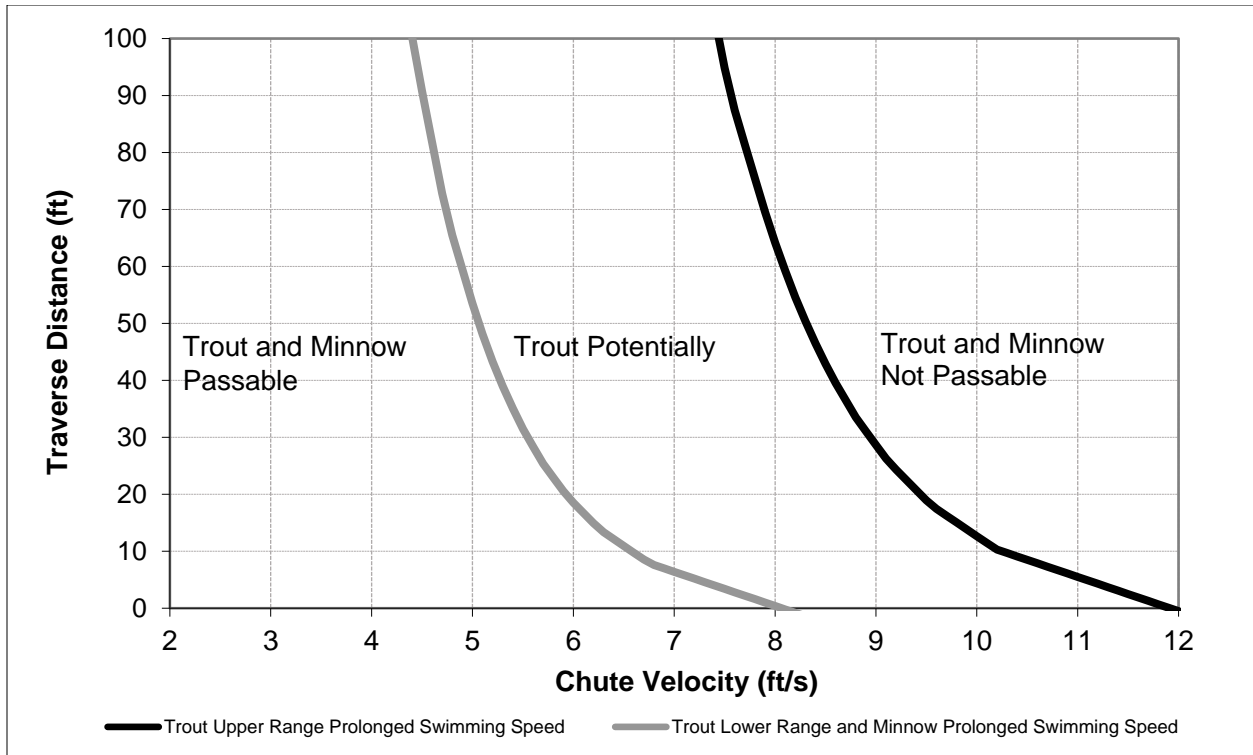
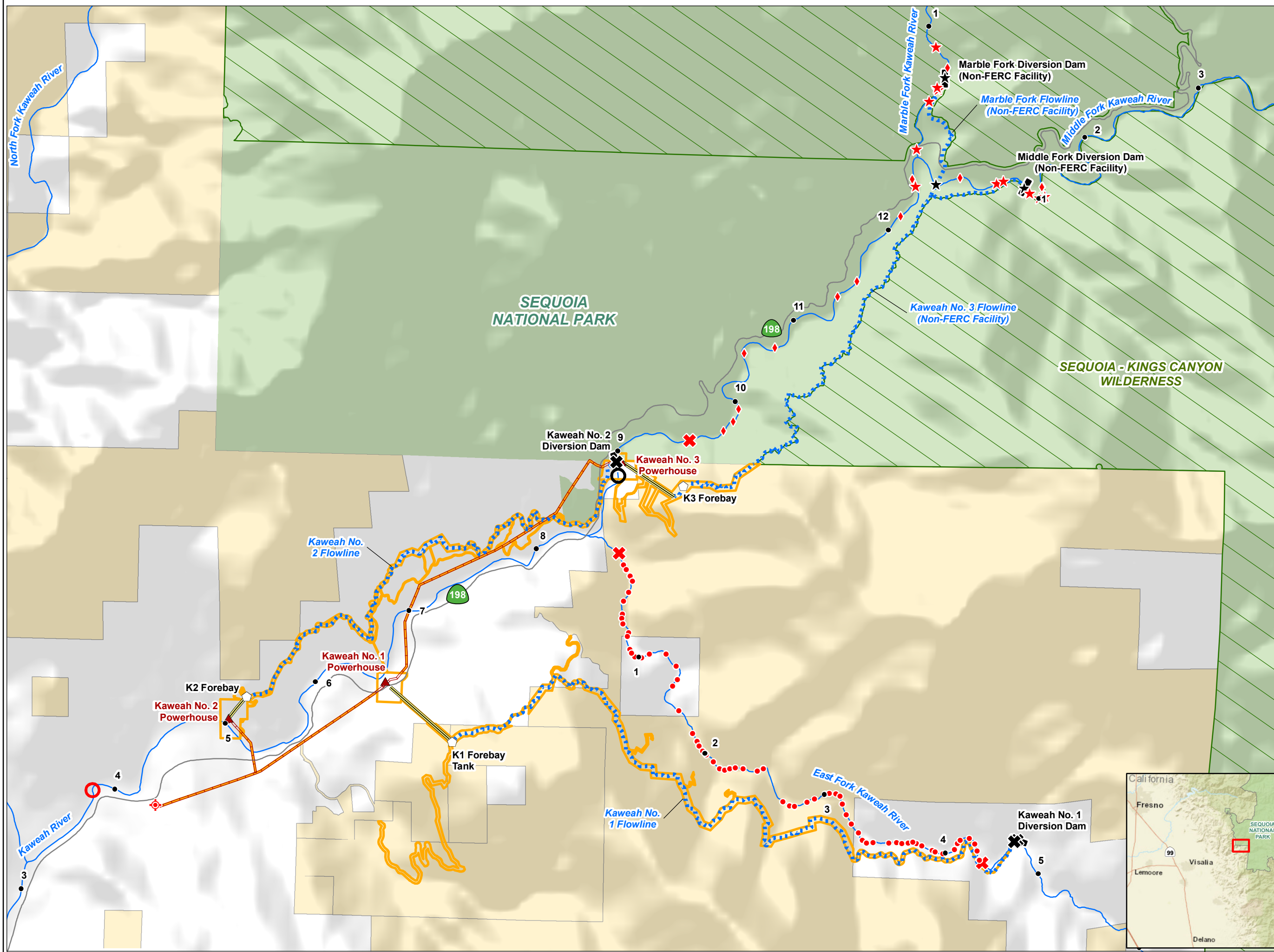

Figure AQ 8-4. Chute Water Velocity vs. Fish Swimming Distance.

This Page Intentionally Left Blank

MAPS

This Page Intentionally Left Blank



- SCE Facilities**
- ▲ Powerhouse
 - Diversion
 - ◻ Forebay
 - ⋯ Flowline
 - ▬ Penstock
 - Transmission Line
 - FERC Boundary
- Other Features**
- Highway/Road
 - Watercourse
 - Water Body
 - River Mile
- Land Jurisdiction***
- Bureau of Land Management
 - National Park Service
 - Private (Blank)
- *SOURCE: BLM 2016
- Land Management**
- ▨ National Wilderness Area
- 2018 Fish Passage Barriers**
- ✘ Impassable Project Barrier
 - ✘ Impassable Natural Barrier
 - Partial Project Barrier
 - Partial Natural Barrier
 - Potential Impassable Barriers ¹
- ¹ Not visited due to inaccessibility
- 2007 Fish Passage Barriers ²**
- ★ Impassable Man-made Barrier
 - ★ Impassable Natural Barrier
 - ◆ Partial Natural Barrier
- ² Barriers from SCE 2007 Report



SOUTHERN CALIFORNIA EDISON
An EDISON INTERNATIONAL® Company

FERC Project No. 298

Map AQ8-1
Kaweah Project
Fish Passage Barrier
Locations and Category



Date: 4/25/2019

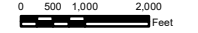

Projection: UTM Zone 11
Datum: NAD 83

Southern California Edison (SCE) has no reason to believe that there are any inaccuracies or defects with information incorporated in this work and make no representations of any kind, including, but not limited to, the warranties of merchantability or fitness for a particular use, nor are any such warranties to be implied, with respect to the information or data, furnished herein. No part of this map may be reproduced or transmitted in any form or by any means, electronic or mechanical, including photocopying and recording system, except as expressly permitted in writing by SCE.

This Page Intentionally Left Blank

APPENDIX A

Quantitative Barrier Assessment Data Sheet

This Page Intentionally Left Blank

Fish Passage Data Sheet SCE

River Reach Surveyed:

Date:

Crew:

Downstream GPS Coordinates:

Upstream GPS Coordinates:

Total Number of Barriers Observed:

General Overview River Photo Numbers:

Detailed Barrier Photo Numbers (list all):

Draw sketch of the river reach or tributary junction surveyed with approximate the location of barriers and photo points labeled. Note: number barriers and photos to correspond to numbers on detailed barrier sheets.

Comments:

River Discharge: _____ cfs

Width (units =)																				
Depth/Elevation (units =)																				
Velocity (units =)																				

Page ___ of ____

Fish Passage Barrier ID (River Reach and Barrier Number):

Date:

Crew:

Barrier location (e.g., GPS Coordinates):

Detailed Barrier Photo Numbers:

Class (circle): Falls Chute Cascade (combination falls/chutes, boulder, turbulent) Critical Riffle

Discharge: _____ cfs

Critical Riffle Measurements and/or Discharge Measurement (circle one)

Width (units =)																							
Depth/Elevation (units =)																							
Velocity (units =)																							

Detailed Barrier Sketch (see images below... use compound falls/chutes or chutes/falls as appropriate). Number each barrier in the order of the measurements recorded below the sketch:

Record the measurements below (with units). Order the measurements as in the sketch if there are multiple chutes/falls.

Fall Measurements

- Width of channel/water at top of crest:
- Water depth at crest (d_{wc}):
- Water velocity at crest (V_{wc}):
- Angle of water at crest ($\pm \theta_{wc}$):
- Fall height (FH):
- Depth of plunge pool (dpp):
- Depth of plunging water (dp):
- Dist. from crest to plunge (X_p):
- Dist. from plunge to standing wave (X_{sw}):

Chute Measurements

- Width of water at crest and in chute:
- Water depth at crest (d_{wc}):
- Water velocity at crest (V_{wc}):
- Angle of water at crest ($\pm \theta_{wc}$):
- Chute height (H):
- Depth of water in chute (d_w):
- Velocity of water in chute (V_{ws}):
- Length of chute slope (LS):
- Slope of chute passage area (Sp):
- Depth of plunge pool (dpp):

Cascade Measurements (Measure each chute/fall)

- Also measure the following
- Resting pool width:
- Resting pool length:
- Resting pool depth:
- Air entrainment %:
- Turbulence (passable or not):

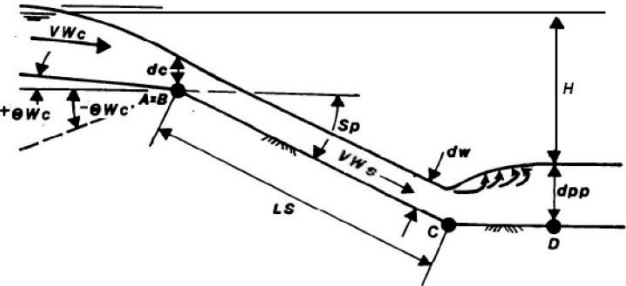
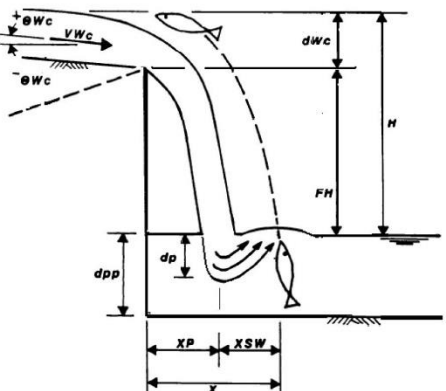

Page ___ of ___

APPENDIX B

Quantitative Fish Barrier Evaluation Approach

This Page Intentionally Left Blank

B.1 Introduction

Upstream passage was evaluated quantitatively using the swimming and leaping capabilities of trout (particularly rainbow trout) and minnows/suckers (hardhead, Sacramento pikeminnow, Sacramento sucker). The upstream fish passage assessment methodology outlined in Powers and Orsborn (1985) and Thompson (1972) was used to evaluate passage at potential vertical barriers, high velocity chutes, and/or critical riffles based on field measurement of the barriers in the field during base flows. Barriers were analyzed for 12-inch (305-mm) trout and minnows/suckers.

B.2 Fish Swimming and Leaping Capabilities

A range of swimming velocity was used for the trout (high- and low-swimming estimates). Minnow and sucker swimming capability was set at the lower end of the trout swimming range. Burst swimming velocity was used to determine the leaping ability of fish (i.e., their ability to navigate vertical barriers). Prolonged and sustained swimming capability was used to determine the ability of fish to navigate high velocity water in chutes and riffles (Powers and Orsborn 1985).

Burst swimming (less than 0.1 minute) was assumed to range between 8 and 12 body lengths/sec for salmonids (trout) (Beamish 1978; Reiser and Peacock 1985; Videler 1993). Burst swimming for cyprinids (minnows) and catostomids (suckers) was set on the lower end of the trout range (8 body lengths/sec). The 60-minute sustained swimming velocity was assumed to be between 2 and 4 body lengths/sec for trout (Brett and Glass 1973; Beamish 1978; Reiser and Peacock 1985) and approximately 2 body lengths/sec for minnows/suckers⁴ (Myrick and Cech 2000; Berry and Pimentel 1985). Prolonged swimming (0.1–60 minutes) was assumed to vary between burst and sustained swimming speed logarithmically (Videler 1993). Figure AQ 8-2 shows the assumed swimming capabilities of fish.

The size of fish used for the analysis was set at a large representative size of 12 inches (305 mm). Throughout the sampled areas (Kaweah River, East Fork Kaweah River, Marble Fork Kaweah River, and Middle Fork Kaweah River), the largest fish measured was about 8.5 inches (216 mm FL). Additionally, snorkel surveys identified one larger rainbow trout in the 10- to 12-inch size class. For fish in the approximately 12-inch and less size, empirical fish leaping data for brook trout indicate that smaller fish (e.g., 6 inches) can leap as high as larger fish (e.g., 8+ inches) (Kondratieff and Myrick 2006). This is partly due to the fact that the maximum swimming speed per body length is higher for smaller fish (e.g., <12 inches) than it is for larger fish (e.g., ≥12 inches) (see compilation of data in Kondratieff and Myrick 2006). As a result, we used the leaping and swimming ability of a 12-inch fish as reasonable representation for the passage capabilities of various-sized fish in the Project Area. The same fish size was used for hardhead, Sacramento pikeminnow, and Sacramento sucker.

A water temperature of 15°C was used to help estimate the approximate 60-minute sustained swimming speed discussed above (Brett and Glass 1973). In general, the effects of water temperature on swimming ability in the range of about 10–20°C are relatively modest (e.g., Myrick and Cech 2000) and water temperature was not used to modify swimming velocity in this analysis.

⁴ Critical swimming velocity data (a laboratory measure of prolonged swimming capacity) for hardhead, Sacramento pikeminnow, Colorado pikeminnow, and Sacramento sucker (Myrick and Cech 2000; Berry and Pimentel 1985) were compared to data for rainbow trout (Beamish 1978; Hawkins and Quinn 1996; Jain et al. 1997). Minnow/sucker species swimming velocities were comparable to the lower range observed for trout (typically about 2 body lengths/sec).

B.3 Vertical Barriers (Falls)

Passage of vertical barriers (falls) requires fish to leap the vertical and horizontal dimensions of the falls. Passage also requires suitable takeoff conditions at the plunge pool and suitable landing conditions at the falls crest.

B.3.1 Vertical and Horizontal Leaping

In order for a fish to clear a leaping barrier they must be able to leap high enough (H) to reach the crest of the barrier and far enough (X) to cover the distance from the standing wave in the plunge pool (the point of optimal leap) to the crest of the barrier. Leaping ability was based on trajectory equations that convert the burst swimming speed of a fish into X and H components (Powers and Orsborn 1985):

$$H = (\tan A) X - g (X)^2 / 2(VF \cos A)^2$$

Where VF is the burst speed of the fish (ft/s), A is the leaping angle, and g is a constant acceleration due to gravity (32.2 ft/sec²). Figure AQ 8-3 shows the vertical and horizontal leaping capability of a 12-inch fish (Note: all potential leaping angles were tested to determine the maximum X distance and H that could be navigated).

Leaping barriers were considered impassable for trout if the barrier could not be cleared at a burst speed of 12 body lengths/sec. Leaping barriers were considered potentially passable for trout if they could be cleared at a burst speed between 8 and 12 body lengths/sec and barriers were considered to be passable if they could be cleared at burst speed of 8 body lengths/sec or less. Leaping barriers were considered impassable for minnows/suckers (e.g., hardhead) if they could not be cleared at a burst velocity greater than 8 body lengths/sec and passable if they could be cleared at a burst velocity of 8 body lengths/sec or less. Table B-1 shows a summary of leaping barrier passability based on fish burst speed.

Table B-1. Leaping Barrier Passability Based on Fish Burst Speed.

Falls Barrier Rating ¹	Burst Speed (body lengths /sec) Required to Leap Barrier	
	Trout	Minnows / Suckers
Passable	≤8	≤8
Potentially Passable	>8–12	NA
Impassable	>12	>8

Note:

¹ Based on Figure AQ 8-3 and burst speeds listed in this table.

B.3.2 Falls Plunge Pool Conditions

If the plunge pool depth was greater than the full body length of a fish, the leaping ability of a fish was assumed to be unhampered. If, however, the plunge pool depth was between 1½ body lengths and/or the penetration of the plunging water reached the bottom of the pool, the leaping ability was assumed to be reduced and the barrier (all else being passable) was deemed only potentially passable. If the plunge pool depth was less than ½ body length, the barrier was deemed impassable. Table B-2 shows a summary of falls barrier passability based on plunge pool conditions.

Table B-2. Falls Barrier Passability Based on Plunge Pool Conditions and Falls Crest Landing Conditions.

Falls Barrier Rating ¹	Plunge Pool Depth	Falls Crest Landing Conditions ²
Passable	≥ full body length of a fish	Depth of the crest was ≥1 times the depth of the fish or the crest ½–<1 times the depth of the fish and sloped downward in the upstream direction and velocity was < than the fish’s burst velocity.
Potentially Passable	½–1 body length or penetration of the plunging water reached the bottom of the pool	Depth of the crest was between 1–½ times the depth of the fish and velocity was < than the fish’s burst velocity.
Impassable	<½ body length	Depth of the crest <½ times depth of the fish or water velocity at the crest was > than the fish’s burst velocity

Notes:

¹ Based on Plunge Pool Depth and Crest Landing Conditions

² Depth of the fish was 0.22 times fish length.

B.3.3 Falls Crest Landing Conditions

If the water velocity at the crest of the falls was greater than the fish’s burst velocity (Figure AQ 8-2), the barrier was classified as impassable. If the crest landing area was deeper than the fish’s body depth, the crest was analyzed as a chute / critical riffle (see below). If the depth of the crest was between 1 and ½ times the depth of the fish and passable as analyzed above, it was considered only potentially passable due to the shallow depth, unless the crest sloped downward in the upstream direction in which case the falls was considered passable. If the crest depth was less than half body depth, the falls was considered impassable. The body depth of fish was assumed to be 0.22 times the length of the fish (USFWS 2008). Refer to Table B-2 showing a summary of fall barrier passability based on crest landing conditions.

B.4 Chute and Critical Riffle Barriers

Fish passage assessment of chute and critical riffle barriers required the water velocity to be less than the upstream distance swimming capabilities of the fish and the depth to be great enough to pass fish.

B.4.1 Water Velocity and Chute Length

If the water velocity of the chute or critical riffle was greater than the fish’s burst velocity (12 body lengths/sec for trout or 8 body lengths/sec for minnows/suckers), it was considered an impassable barrier. If the water velocity was less than the fish’s sustained velocity, 2 body lengths/sec (for both trout and minnows/suckers) the barrier was classified as passable. Otherwise, if the velocity was between the burst and sustained velocity, the prolonged swimming speed equation was used to determine if the fish could pass the length of the barrier (see Figure AQ 8-2). For minnows/suckers, the lower velocity swimming equation was used. For trout, both the high and low velocity equations were used. If the barrier could be navigated with the lower velocity equation, it was considered passable. If the barrier could only be navigated using the higher velocity equation, the barrier was considered potentially passable. Table B-3 shows a summary of chute and critical riffle barrier passability based on water velocity and depth and chute length.

Table B-3. Summary of Chute and Critical Riffle Barrier Passability Based on Water Velocity, Water Depth, and Chute Length.

Chute Barrier Rating ¹	Water Velocity and Length	Water Depth
Passable	Water velocity < fish's sustained velocity (2 body lengths/sec) or fish's prolonged velocity / swimming distance relationship exceeded velocity / length of chute (see Figure AQ 8-4)	Depth ≥1 times the depth of the fish
Potentially Passable	NA	Depth was ½–1 times the fish's body length
Impassable	Water velocity > fish's burst velocity (8 body lengths/sec for minnows/suckers or 12 body lengths/sec for trout) or fish's prolonged velocity / swimming distance relationship was < than the velocity / length of chute (see Figure AQ 8-4)	Depth was <½ times fish's body depth

Note:

¹ Based on Listed Water Velocity, Length, and Depth Conditions

B.4.2 Depth

If the water velocity of a chute or riffle was determined to be passable, but the water depth was between 1 ½ times the fish's body depth, swimming ability was assumed to be impaired and the barrier was classified as potentially passable. If the water depth was less than half times the fish's body depth, the barrier was classified as impassable.

B.5 **References**

- Beamish, F.W.H. 1978. Swimming Capacity. In Fish Physiology, vol. 7. (eds. W.S. Hoar and D.J. Randall), pp. 101-187. Academic Press, New York.
- Berry, C.R., and R. Pimentel. 1985. Swimming Performances of Three Rare Colorado River Fishes. Transactions of the American Fisheries Society 114:397-402.
- Brett, J.R., and N.R. Glass. 1973. Metabolic rates and critical swimming speeds of sockeye salmon (*Oncorhynchus nerka*) in relation to size and temperature. J. Fish. Res. Bd Can. 30, 379-387.
- Hawkins, D.K., and T.P. Quinn. 1996. Critical Swimming Velocity and Associated Morphology of Juvenile Coastal Cutthroat Trout (*Oncorhynchus clarki clarki*), and Steelhead Trout (*Oncorhynchus mykiss*), and their Hybrids. Can. J. Fish. Aquat. Sci. 53:1487-1496.
- Jain, K.E., J.C. Hamilton, and A.P. Farrell. 1997. Use of Ramp Velocity Test to Measure Critical Swimming Speed in Rainbow Trout (*Oncorhynchus mykiss*). Comp. Biochem. Physiol. 117A:441-444.
- Kondratieff, M.C., and C.A. Myrick. 2006. How high can brook trout jump? A laboratory evaluation of brook trout jumping performance. Transaction of the American Fisheries Society. 135: 361-370.
- Myrick, C.A. and J.J. Cech, Jr. 2000. Swimming performances of four California stream fishes: temperature effects. Env. Biol. Fish. 58: 289-295.

- Powers, P.D., and J.F. Orsborn. 1985. Analysis of Barriers to Upstream Migration: An Investigation of the Physical and Biological Conditions Affecting Fish Passage Success at Culverts and Waterfalls. BPA Report No. DOE/BP-36523-1.
- Reiser, D.W., and R.T. Peacock. 1985. A Technique for Assessing Upstream Fish Passage Problems at Small-Scale Hydropower Developments. Symposium on Small Hydropower and Fisheries. May 1-3.
- Thompson, K. 1972. Determining Stream Flows for Fish Life in Pacific Northwest River Basins Commission Instream Flow Requirements Workshop, March 15-16.
- United States Department of Fish and Wildlife Service (USFWS). 2008 FishXing Software and Learning Systems for Fish Passage through Culverts. Accessed 2008.
<http://www.stream.fs.fed.us/fishxing/beta.html>.
- Videler, J.J. 1993. Fish Swimming. London, Chapman & Hall.

This Page Intentionally Left Blank

APPENDIX C

Detailed Fish Passage Barrier Descriptions

This Page Intentionally Left Blank

Table of Contents

Downstream of National Park Foothills Visitor Center (Natural Barrier)	C-3
Kaweah No. 2 Diversion Dam (Project Barrier)	C-4
Kaweah No. 2 Diversion Dam Gage Pool Weir (Project Barrier)	C-5
Downstream of Kaweah No. 2 Powerhouse (Natural Barrier)	C-6
Kaweah No. 1 Diversion Dam (Project Barrier)	C-8
Kaweah No. 1 Diversion Dam Gage Pool Weir (Project Barrier)	C-9
East Fork Kaweah Downstream of Kaweah River Bridge (Natural Barrier)	C-11
East Fork Kaweah above Confluence (Natural Barrier)	C-13

List of Tables

Table C-1.	Downstream of National Park Foothills Visitor Center (Natural Barrier) fall measurements.	C-3
Table C-2.	Kaweah No. 2 Diversion Dam (Project Barrier) fall measurements.....	C-4
Table C-3.	Kaweah No. 2 Diversion Dam Gage Pool Weir (Project Barrier) fall measurements.	C-5
Table C-4.	Downstream of Kaweah No. 2 Powerhouse (Natural Barrier) fall measurements.	C-7
Table C-5.	Kaweah No. 1 Diversion Dam (Project Barrier) fall measurements.....	C-8
Table C-6.	Kaweah No. 1 Diversion Dam Gage Pool Weir (Project Barrier) fall measurements.	C-10
Table C-7.	Kaweah No. 1 Diversion Dam Gage Pool Weir (Project Barrier) left bank chute measurements.	C-10
Table C-8.	Kaweah No. 1 Diversion Dam Gage Pool Weir (Project Barrier) right bank chute measurements.	C-10
Table C-9.	East Fork Kaweah Downstream of Kaweah River Bridge (Natural Barrier) fall measurements.	C-12
Table C-10.	East Fork Kaweah above Confluence (Natural Barrier) right bank fall measurements.	C-14
Table C-11.	East Fork Kaweah above Confluence (Natural Barrier) left bank chute measurements.	C-14

List of Figures

Figure C-1.	Left: Image of natural barrier downstream of National Park Foothills Visitor Center. Right: Inset image of a portion of the falls with kayaker for scale.....	C-3
Figure C-2.	Image of project barrier at Kaweah No. 2 Diversion Dam.	C-4
Figure C-3.	Image across width of stream at entire project barrier at Kaweah No. 2 Diversion Dam Gage Pool Weir.	C-5
Figure C-4.	TOP: Overview image of natural barrier downstream of Kaweah No. 2 Powerhouse. BOTTOM: Image of natural barrier downstream of Kaweah No. 2 Powerhouse.	C-6
Figure C-5.	Image of project barrier at Kaweah No. 1 Diversion Dam.	C-8
Figure C-6.	TOP: Image of project barrier at Kaweah No. 1 Diversion Dam Gage Pool Weir. Kaweah No. 1 Diversion Dam project barrier is visible in background. BOTTOM: Image across width of project barrier at Kaweah No. 1 Diversion Dam Gage Pool Weir towards the right bank.	C-9
Figure C-7.	TOP: Overview image of natural barrier on East Fork Kaweah downstream of Kaweah River Bridge. BOTTOM: Image of natural barrier on East Fork Kaweah downstream of Kaweah River Bridge.....	C-11
Figure C-8.	TOP: Image of natural barrier on the East Fork Kaweah above the confluence with Kaweah River. Right bank falls and the bottom of the left bank bedrock chute in view. BOTTOM: Image of the left bank bedrock chute and the upper section of the right bank falls.	C-13

DOWNSTREAM OF NATIONAL PARK FOOTHILLS VISITOR CENTER (NATURAL BARRIER)

Survey Date: November 29, 2018
 Survey Time: 1500
 Survey Flow: NA
 GPS Coordinates: 36.48809, -118.82769
 Class: Falls

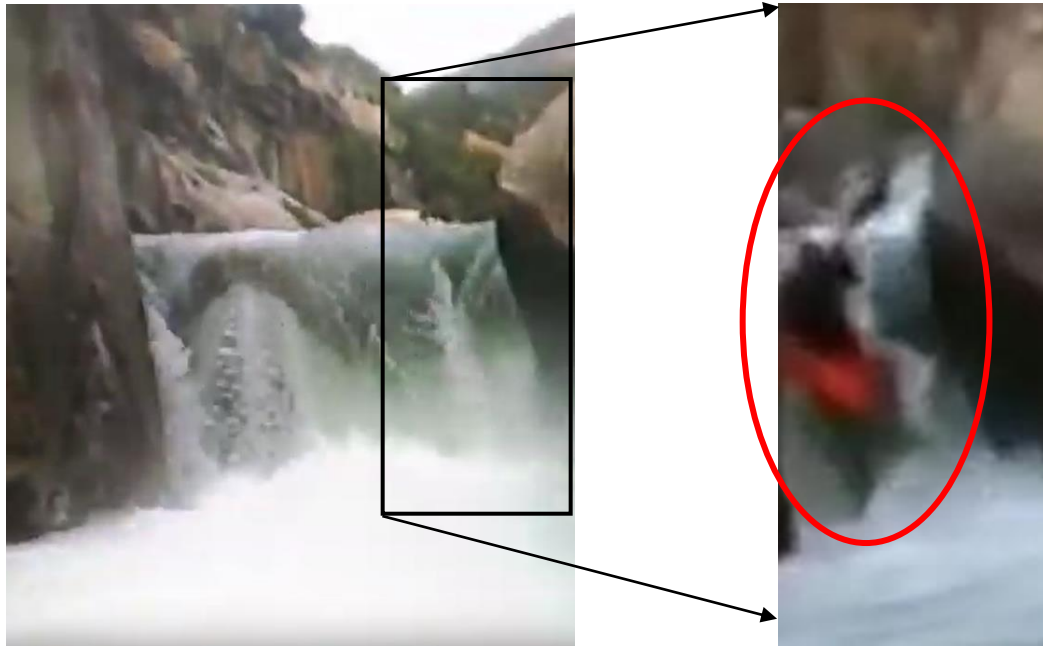

Figure C-1. Left: Image of natural barrier downstream of National Park Foothills Visitor Center. Right: Inset image of a portion of the falls with kayaker for scale. Notice the rock on right side of both images for orientation. Red circle indicates kayaker.

Table C-1. Downstream of National Park Foothills Visitor Center (Natural Barrier) fall measurements.

Width of channel/water at top of crest in feet:	12	
Water depth at crest in feet (dWc):	2	
Water velocity at crest in feet per second (VWc):	-	
Angle of water at crest ($\pm \theta Wc$):	-	
Fall height in feet (FH):	10	
Depth of plunge pool in feet (dpp):	-	
Depth of plunging water in feet (dp):	-	
Distance from crest to plunge in feet (Xp):	8	
Distance from plunge to standing wave in feet (XSW):	4	

Measurements estimated from photographs, too dangerous to access.

Note: Images obtained from kayaker videos online (URL: <https://www.youtube.com/watch?v=zHNBgarNLp4>). Date and time when images were taken is unknown.

KAWEAH NO. 2 DIVERSION DAM (PROJECT BARRIER)

Survey Date: November 29, 2018
 Survey Time: 1315
 Survey Flow: 338 cfs
 GPS Coordinates: 36.48597, -118.83603
 Class: Diversion Dam Falls



Figure C-2. Image of project barrier at Kaweah No. 2 Diversion Dam.
Staff holding stadia rod on left side of image for scale.

Table C-2. Kaweah No. 2 Diversion Dam (Project Barrier) fall measurements.

Width of channel/water at top of crest in feet:	60	
Water depth at crest in feet (dWc):	0.8	
Water velocity at crest in feet per second (VWc):	2.2	
Angle of water at crest ($\pm \theta Wc$):	<1	
Fall height in feet (FH):	9.2	
Depth of plunge pool in feet (dpp):	5	
Depth of plunging water in feet (dp):	5	
Distance from crest to plunge in feet (Xp):	13	
Distance from plunge to standing wave in feet (XSW):	3	

KAWEAH NO. 2 DIVERSION DAM GAGE POOL WEIR (PROJECT BARRIER)

Survey Date: November 29, 2018
 Survey Time: 1400
 Survey Flow: 315 cfs
 GPS Coordinates: 36.484799, -118.835709
 Class: Gage Weir Falls



Figure C-3. Image across width of stream at entire project barrier at Kaweah No. 2 Diversion Dam Gage Pool Weir.
Circled portion identifies location of measurements.

Table C-3. Kaweah No. 2 Diversion Dam Gage Pool Weir (Project Barrier) fall measurements.

Width of channel/water at top of crest in feet:	27	
Water depth at crest in feet (dWc):	0.6	
Water velocity at crest in feet per second (VWc):	2.2	
Angle of water at crest ($\pm \theta Wc$):	<1	
Fall height in feet (FH):	1	
Depth of plunge pool in feet (dpp):	5.2	
Depth of plunging water in feet (dp):	3	
Distance from crest to plunge in feet (Xp):	1.5	
Distance from plunge to standing wave in feet (XSW):	1.5	

Note: Measurements taken on left bank weir barrier. Barriers in center and right bank are more substantial and were not included in measurements.

DOWNSTREAM OF KAWEAH NO. 2 POWERHOUSE (NATURAL BARRIER)

Survey Date: November 30, 2018

Survey Time: 1245

Survey Flow: 169.4 cfs

GPS Coordinates: 36.454732, -118.895203

Class: Falls



Figure C-4. TOP: Overview image of natural barrier downstream of Kaweah No. 2 Powerhouse. BOTTOM: Image of natural barrier downstream of Kaweah No. 2 Powerhouse.

Barrier site consisted of multiple variable size falls and side channels spanning the width of the river. The measurements in Table C-4 only reflect the falls indicated by the red arrows.

Table C-4. Downstream of Kaweah No. 2 Powerhouse (Natural Barrier) fall measurements.

Width of channel/water at top of crest in feet:	3	
Water depth at crest in feet (dWc):	1.3	
Water velocity at crest in feet per second (VWc):	0.64	
Angle of water at crest ($\pm \theta Wc$):	<1	
Fall height in feet (FH):	1.8	
Depth of plunge pool in feet (dpp):	2.3	
Depth of plunging water in feet (dp):	2.3	
Distance from crest to plunge in feet (Xp):	13	
Distance from plunge to standing wave in feet (XSW):	7	

Note: Left bank side channel easily passable at mid to high flows behind staff holding stadia rod.

KAWEAH NO. 1 DIVERSION DAM (PROJECT BARRIER)

Survey Date: November 29, 2018
 Survey Time: 1035
 Survey Flow: 188 cfs
 GPS Coordinates: 36.45165, -118.78932
 Class: Diversion Dam Falls



Figure C-5. Image of project barrier at Kaweah No. 1 Diversion Dam.
Staff with stadia rod on left bank for scale.

Table C-5. Kaweah No. 1 Diversion Dam (Project Barrier) fall measurements.

Width of channel/water at top of crest in feet:	23	
Water depth at crest in feet (dWc):	6	
Water velocity at crest in feet per second (VWc):	2.5	
Angle of water at crest ($\pm \theta Wc$):	<1	
Fall height in feet (FH):	11.5	
Depth of plunge pool in feet (dpp):	8	
Depth of plunging water in feet (dp):	6	
Distance from crest to plunge in feet (Xp):	13	
Distance from plunge to standing wave in feet (XSW):	2	

KAWEAH NO. 1 DIVERSION DAM GAGE POOL WEIR (PROJECT BARRIER)

Survey Date: November 29, 2018
Survey Time: 1230
Survey Flow: 122 cfs
GPS Coordinates: 36.451590, -118.789691
Class: Gage Weir Falls/Chute



Figure C-6. TOP: Image of project barrier at Kaweah No. 1 Diversion Dam Gage Pool Weir. Kaweah No. 1 Diversion Dam project barrier is visible in background. BOTTOM: Image across width of project barrier at Kaweah No. 1 Diversion Dam Gage Pool Weir towards the right bank.

Image shows above angle with left bank falls into immediate chute and larger right bank chute.

Table C-6. Kaweah No. 1 Diversion Dam Gage Pool Weir (Project Barrier) fall measurements.

Width of channel/water at top of crest in feet:	35	
Water depth at crest in feet (dWc):	0.8	
Water velocity at crest in feet per second (VWc):	3	
Angle of water at crest ($\pm \theta Wc$):	<1	
Fall height in feet (FH):	5.2	
Depth of plunge pool in feet (dpp):	0.5	
Depth of plunging water in feet (dp):	0.5	
Distance from crest to plunge in feet (Xp):	1	
Distance from plunge to standing wave in feet (XSW):	0	

Table C-7. Kaweah No. 1 Diversion Dam Gage Pool Weir (Project Barrier) left bank chute measurements.

Width of water at crest and in chute in feet:	35	
Water depth at crest in feet (dWc):	0.5	
Water velocity at crest in feet per second (VWc):	-	
Angle of water at crest ($\pm \theta Wc$):	20	
Chute height in feet (H):	2	
Depth of water in chute in feet (dW):	0.5	
Velocity of water in chute in feet per second (VWs):	>12	
Length of chute slope in feet (LS):	10.2	
Slope of chute passage area (Sp):	20	
Depth of plunge pool in feet (dpp):	2.5	

Table C-8. Kaweah No. 1 Diversion Dam Gage Pool Weir (Project Barrier) right bank chute measurements.

Width of water at crest and in chute in feet:	5	
Water depth at crest in feet (dWc):	0.5	
Water velocity at crest in feet per second (VWc):	>3	
Angle of water at crest ($\pm \theta Wc$):	<1	
Chute height in feet (H):	7.2	
Depth of water in chute in feet (dW):	0.5	
Velocity of water in chute in feet per second (VWs):	>12	
Length of chute slope in feet (LS):	17	
Slope of chute passage area (Sp):	48	
Depth of plunge pool in feet (dpp):	2.5	

Measurements estimated while in the field, chute not safely accessible.

EAST FORK KAWEAH DOWNSTREAM OF KAWEAH RIVER BRIDGE (NATURAL BARRIER)

Survey Date: November 29, 2018

Survey Time: 0950

Survey Flow: 195 cfs

GPS Coordinates: 36.44956, -118.79332

Class: Falls



Figure C-7. TOP: Overview image of natural barrier on East Fork Kaweah downstream of Kaweah River Bridge. BOTTOM: Image of natural barrier on East Fork Kaweah downstream of Kaweah River Bridge.

Staff is holding the stadia rod at the base of fall on the surface of the water. The red arrow identifies the 14-foot mark on the stadia rod.

Table C-9. East Fork Kaweah Downstream of Kaweah River Bridge (Natural Barrier) fall measurements.

Width of channel/water at top of crest in feet:	20	
Water depth at crest in feet (dWc):	2	
Water velocity at crest in feet per second (VWc):	4	
Angle of water at crest ($\pm \theta Wc$):	<5	
Fall height in feet (FH):	9	
Depth of plunge pool in feet (dpp):	6	
Depth of plunging water in feet (dp):	6	
Distance from crest to plunge in feet (Xp):	10	
Distance from plunge to standing wave in feet (XSW):	10	

EAST FORK KAWEAH ABOVE CONFLUENCE (NATURAL BARRIER)

Survey Date: November 30, 2018

Survey Time: 1050

Survey Flow: 46.5 cfs

GPS Coordinates: 36.47766, -118.83567

Class: Falls/ Chute



Figure C-8. TOP: Image of natural barrier on the East Fork Kaweah above the confluence with Kaweah River. Right bank falls and the bottom of the left bank bedrock chute in view. BOTTOM: Image of the left bank bedrock chute and the upper section of the right bank falls.

Table C-10. East Fork Kaweah above Confluence (Natural Barrier) right bank fall measurements.

Width of channel/water at top of crest in feet:	4	
Water depth at crest in feet (dWc):	2	
Water velocity at crest in feet per second (VWc):	3.8	
Angle of water at crest ($\pm \theta Wc$):	<3	
Fall height in feet (FH):	5.7	
Depth of plunge pool in feet (dpp):	4	
Depth of plunging water in feet (dp):	4	
Distance from crest to plunge in feet (Xp):	11	
Distance from plunge to standing wave in feet (XSW):	4	

Table C-11. East Fork Kaweah above Confluence (Natural Barrier) left bank chute measurements.

Width of water at crest and in chute in feet:	4	
Water depth at crest in feet (dWc):	2	
Water velocity at crest in feet per second (VWc):	3.8	
Angle of water at crest ($\pm \theta Wc$):	<3	
Chute height in feet (H):	9.7	
Depth of water in chute in feet (dW):	0.5	
Velocity of water in chute in feet per second (VWs)	12.2	
Length of chute slope in feet (LS):	35.8	
Slope of chute passage area (Sp):	22	
Depth of plunge pool in feet (dpp):	3	

Measurements estimated while in the field, chute not safely accessible.

APPENDIX D

River Gradient Plots

This Page Intentionally Left Blank

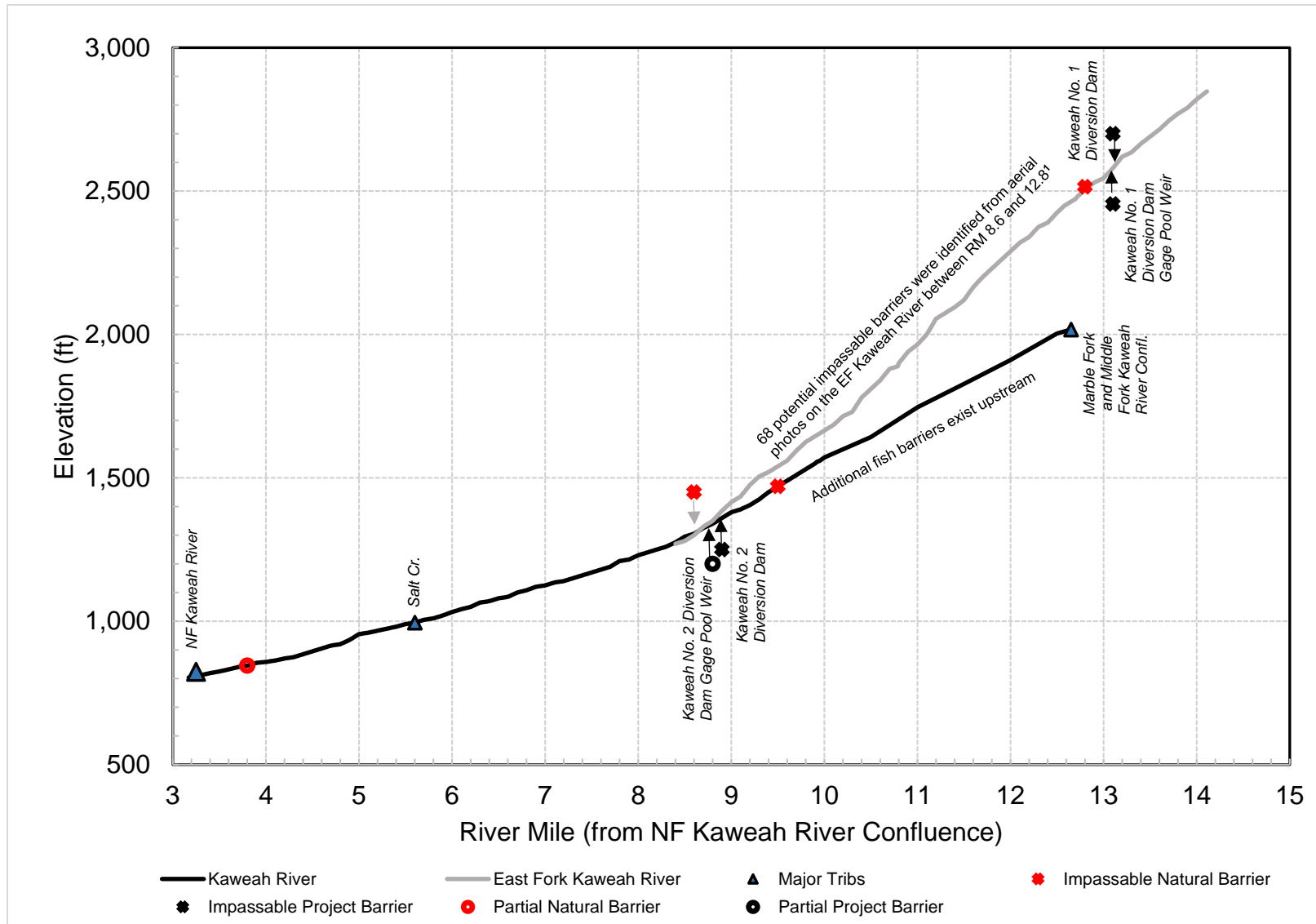

¹Additional barriers are shown on Map AQ 8-1

Figure D-1. Longitudinal Profile of River Gradient and Fish Passage Barriers on the Kaweah River.

This Page Intentionally Left Blank

Kaweah Project, FERC Project No. 298

AQ 9 – Entrainment Draft Technical Study Report

December 2019



Southern California Edison Company
Regulatory Support Services
1515 Walnut Grove Avenue, Rosemead, CA 91770

Table of Contents

- 1 Introduction1**
- 2 Study Objectives1**
- 3 Extent of Study Area1**
- 4 Study Approach.....1**
 - 4.1 Project Facilities Characterization 2
 - 4.2 Direct Entrainment Sampling..... 2
 - 4.3 Effects of Entrainment 3
- 5 Study Results4**
 - 5.1 Project Facilities Characterization 4
 - 5.1.1 Kaweah No. 1 Development 4
 - 5.1.2 Kaweah No. 2 Development 4
 - 5.1.1 Kaweah No. 3 Development 5
 - 5.2 Direct Entrainment Sampling..... 6
 - 5.2.1 Kaweah No. 1 Flowline 6
 - 5.2.2 Kaweah No. 2 Flowline 7
 - 5.2.3 Kaweah No. 3 Flowline 7
 - 5.3 Effects of Entrainment 7
 - 5.3.1 Fish Population 7
- 6 Literature Cited.....8**

List of Tables

- Table AQ 9-1. Proposed entrainment field schedule (also see Application for New License Section 4, Appendix 4-A Entrainment Study Measure). 1
- Table AQ 9-2a. Flow statistics for stream gages and flowlines associated with the Kaweah Project for the available period of record (1994-2018). 2
- Table AQ 9-2b. Percent of flow diverted at each flowline for the period of record (1994-2018). 6
- Table AQ 9-3. Estimated maximum intake velocity at the Kaweah No. 1 and Kaweah No. 2 Flowline intake screens..... 7
- Table AQ 9-4. Summary of fyke net entrainment sampling results in the Kaweah Project flowlines in 2019. Appendix A contains each individual sampling period results. 8
- Table AQ 9-5. Summary of drift net entrainment sampling results in the Kaweah Project flowlines in 2019. Appendix A contains each individual sampling period results. 9
- Table AQ 9-6. Summary of reach density for all captured species excluding rainbow trout..... 10
- Table AQ 9-7. Reach density and reach biomass of rainbow trout..... 11

List of Figures

Figure AQ 9-1. Aerial view of the Kaweah No. 1 Flowline Intake with key features labeled.	1
Figure AQ 9-2. The Kaweah No. 1 Flowline Intake, immediately upstream of the Kaweah No. 1 Diversion (top – intake trash screen; bottom left – diversion dam; bottom right – looking down on intake and slide gate gear).	2
Figure AQ 9-3. A view of the Kaweah No. 1 Flowline Conduit Outlet into the sandbox.	3
Figure AQ 9-4. Kaweah No. 1 Flowline Fishwheel.	4
Figure AQ 9-5. Kaweah No. 1 Forebay Tank.	5
Figure AQ 9-6. Aerial view of the Kaweah No. 2 Flowline Intake with key feature labeled.	5
Figure AQ 9-7. The Kaweah No. 2 Flowline Intake, immediately upstream of the Kaweah No. 2 Diversion Dam. Flow is from right to left in the image.	6
Figure AQ 9-8. Detail, looking down on the Kaweah No. 2 Flowline Intake Grate. Flow is from right to left in the image.	7
Figure AQ 9-9. Kaweah No. 2 Flowline Fishwheel.	8
Figure AQ 9-10. Kaweah No. 2 Forebay, Flume and Penstock, and Drains.	8
Figure AQ 9-11. Aerial view of the Kaweah No. 3 Flowline, Forebay, Drains, and Penstock.	9
Figure AQ 9-12. Fyke net and live car set up at Kaweah No. 1 Flowline (left image looking upstream, right image looking downstream). Flow approximately 7.2 cfs.	9
Figure AQ 9-13. Drift net with 12-inch by 17-inch rectangular opening deployed in Kaweah No. 1 Flowline immediately downstream of the flowline sampling section where the flowline water was returned back to the East Fork Kaweah River. Flow approximately 6.2 cfs.	10
Figure AQ 9-14. Kaweah No. 2 Flowline fyke net and drift net sampling location.	11
Figure AQ 9-15. Fyke net with wing walls and live car set up at Kaweah No. 2 Flowline.	12
Figure AQ 9-16. Three drift nets with 6-inch diameter opening deployed in Kaweah No. 2 Flowline at a wooden bridge immediately upstream of the fyke trap location.	13
Figure AQ 9-17. Juvenile Sacramento pikeminnow caught in the fyke trap during the late spring sampling at Kaweah No. 2 Flowline.	14
Figure AQ 9-18. Three drift nets with 6-inch diameter opening deployed at a wooden bridge immediately upstream of the Kaweah No. 3 Forebay.	15

List of Maps

Map AQ 9-1. Kaweah Project Entrainment Study Sampling Locations.	1
---	---

List of Appendices

Appendix A Individual Sampling Period Results	
---	--

List of Acronyms

ac-ft	acre-feet
cfs	cubic feet per second
FERC	Federal Energy Regulatory Commission
ft	foot/feet
lbs	pounds
mm	millimeter
msl	mean sea level
MW	megawatt
PCWA	Placer County Water Agency
PIT	Passive Integrated Transponder
Project	Kaweah Project
PSP	Proposed Study Plan
RSP	Revised Study Plan
SCE	Southern California Edison Company
SNP	Sequoia National Park
TL	total length
TSP	Technical Study Plan
TSR	Technical Study Report
TWG	Technical Working Group
USGS	U.S. Geological Survey
YOY	young-of-year

This Page Intentionally Left Blank

1 INTRODUCTION

This Technical Study Report (TSR) describes the data and findings developed by Southern California Edison Company (SCE) in association with implementation of the AQ 9 – Entrainment Technical Study Plan (AQ 9 – TSP) for the Kaweah Project, FERC Project No. 298 (Project). The AQ 9 – TSP was included in SCE's Revised Study Plan (RSP)¹ (SCE 2017a) and was approved by the Federal Energy Regulatory Commission (FERC) on October 24, 2017 as part of its Study Plan Determination for the Project (FERC 2017). Initial entrainment sampling conducted June, 2018 at the Kaweah No. 3 Flowline identified some infrastructure issues at the sampling site. Entrainment sampling was delayed until a revised study plan that included new entrainment study sites and measures to protect flowline infrastructure could be developed. The AQ 9 – TSP was revised and approved on December 5, 2018, and filed electronically with FERC on December 11, 2018. Because entrainment sampling will not be completed prior to filing of the Kaweah Project Application for New License (December 2019), SCE and key resource agencies met to collaborate on a modified schedule and approach for completing and reporting the AQ 9 – TSP. On December 3 and December 10, 2019, SCE met with the California Department of Fish and Wildlife (CDFW) and the State Water Resources Control Board (State Water Board) and reached agreement on a proposed approach. Consistent with direction from FERC staff, SCE filed the proposed approach in a letter to FERC (Comments on Updated Study Report Meeting Summary, December 19, 2019) and included the Entrainment Study Measure in Exhibit E, Section 4, Appendix 4-A of the Application for New License. Details of the AQ 9 – TSP components completed to date and the modified schedule and approach are provided below.

2 STUDY OBJECTIVES

The AQ 9 – TSP includes three study objectives, as follows:

- Characterize Project diversions, flowlines, powerhouse turbines, and operations in relation to factors that may affect entrainment or mortality.
- Directly estimate the potential for entrainment and mortality by sampling fish entrained in the Project flowlines.
- Develop information necessary to assess potential fish population/production effects of entrainment.

3 EXTENT OF STUDY AREA

The study area for characterization of the Project diversions and powerhouse turbines includes the three Project flowlines (Kaweah Flowline Nos. 1, 2, and 3) and powerhouses (Kaweah Powerhouse Nos. 1, 2, and 3; see Map AQ 9-1).

4 STUDY APPROACH

Study elements described in the revised AQ 9 – TSP were initiated in 2019. Table AQ 9-1 identifies the proposed schedule for completion of the entrainment sampling. As identified in the Revised AQ 9 – TSP, sampling at Kaweah No. 1 Flowline cannot be initiated until the flowline is repaired². The flowline repair is currently scheduled to be completed in summer 2020, which means the entrainment sampling would not be completed prior to filing of the Kaweah Project Application for New License (December 2019). Also,

¹ SCE filed a Proposed Study Plan (PSP) on May 24, 2017 (SCE 2017b). Three comments were filed on the PSP, however, they did not result in revisions to any of the study plans. Therefore, SCE filed a Revised Study Plan (RSP) on September 19, 2017, which stated that the PSP, without revision, constituted its RSP. The FERC subsequently issued a Study Plan Determination on October 24, 2017 approving all study plans for the Kaweah Project.

² Due to a landslide that damaged the Kaweah No. 1 Flowline, the Project is currently not diverting water from the East Fork Kaweah River. The timing of the entrainment study on the Kaweah No. 1 Flowline is contingent upon repair.

sampling in the Kaweah No. 2 Flowline and Kaweah No. 3 Flowline, while partially complete, would not be complete prior to filing of the Kaweah Project Application for New License. As a result, completion and reporting of the entrainment sampling will occur in two phases. Sampling in the Kaweah No. 2 Flowline will be completed by April 2020 and will be reported along with the sampling that has been completed in the Kaweah No. 3 Flowline in a Final AQ 9 – Technical Study Report in 2020. Sampling in the Kaweah No. 1 Flowline will be completed within 18 months of issuance of the new license and reported in a Supplemental AQ 9 – Technical Study Report (see Application for New License Exhibit E, Section 4, Appendix 4-A Entrainment Study Measure). Elements of the AQ 9 – TSP that have been completed to date are provided below in this draft report and the study approach for those elements is presented in the following sections.

4.1 Project Facilities Characterization

Characterization of the Project diversion structures and intakes, flowlines, diversion operations, and powerhouse turbines included in this report consisted of the following:

- Figures depicting the location of the Project diversion facilities;
- Photographs of each diversion structure and flowline;
- Summaries of monthly exceedance flows at each diversion facility for both inflows and bypass flows and for the percent of flows diverted;
- Calculated intake velocity fields at each intake structure over the range of potential inflows;
- Descriptions of the powerhouse turbines; and
- Characterization of literature-based turbine fish survival estimates.

4.2 Direct Entrainment Sampling

Direct entrainment sampling as determined by the Aquatic Technical Working Group (TWG) consisted of the following approach and special considerations:

- Sampling was to be conducted during four representative sampling periods, when Project diversions were operating. The four sampling periods include: (1) January/February (winter), (2) March/April (early spring), (3) May/June (late spring), and (4) July (summer).
- Special considerations related to the Kaweah No. 1 and No. 3 flowlines:
 - Due to a landslide that damaged the Kaweah No. 1 Flowline in July 2018, the Project is currently not diverting water from the East Fork Kaweah River. At the top of the flowline near the diversion, however, the infrastructure allowed the potential to sample entrainment. Flow diverted into the flowline could be returned to the river at a flow turn-out approximately 50 yards downstream without impacting the damaged flowline farther downstream. Sampling was initiated during spring 2019 at the top of the flowline. Details are reported in the results section; however, due to intractable issues with the landowner, the sampling was abandoned until the flowline can be repaired and sampling can occur at a more secure location. The current schedule for the repair of the Kaweah No. 1 Flowline is summer 2020. Based on the Entrainment Study Measure (Application for New License, Exhibit E, Section 4, Appendix 4-A), entrainment sampling would be initiated the winter, early spring, late spring, and summer following issuance of the new license (sampling will be completed within 18 months of license issuance).
 - Initial entrainment sampling was conducted in Kaweah No. 2 and No. 3 flowlines using fyke nets on June 19-20, 2018. Sampling in Kaweah No. 3 Flowline resulted in some overtopping and undermining of the flowline upstream of the Kaweah No. 3 Forebay and termination of the entrainment sampling. Post study review identified potential high risk of damage to infrastructure

and the environment related to entrainment sampling in the Kaweah No. 3 flowline. Issues of concern were: (1) inadequate freeboard in the flowline at full diversion capacity when the sampling net is placed in the flowline; (2) steep topography along the flowline; (3) remote sampling locations; and (4) lack of access to equipment to assist in installing, cleaning, and removing entrainment nets.

Due to the high risk associated with Kaweah No. 3 Flowline, the revised study design included entrainment monitoring in the Kaweah No. 1 and No. 2 flowlines to approximate entrainment in Kaweah No. 3 Flowline. Drift net sampling for larval fish in Kaweah No. 3 flowline, however, was still conducted (see below).

- For each of the four entrainment sampling periods:
 - Entrainment was sampled for three consecutive days (12 hours/day) during each sample period according to the following schedule:
 - 8:00 am – 1:00 pm time window, sample 4 hours.
 - 3:00 pm – 8:00 pm time window, sample 4 hours.
 - 10:00 pm – 3:00 am time window, sample 4 hours.
 - During each sampling period, sampling was conducted at approximately 50% diversion capacity or potentially greater, depending on site-specific safety conditions (i.e., debris, canal freeboard). Safe sampling conditions for the infrastructure and staff was determined by the fish sampling crew and SCE maintenance staff in the field and was the primary factor used to set the sampling flow.
 - Sampling was conducted for adult and juvenile fish using a modified Kodiak trawl or fyke net in Kaweah No. 1 and Kaweah No. 2 flowlines. In addition, sampling was conducted for fry using drift nets in the Kaweah No. 1, Kaweah No. 2, and Kaweah No. 3 flowlines. The proportion of flow sampled by each net was measured, if the entire flow was not sampled.
 - All entrained fish were identified, enumerated, and measured (length) and their status (uninjured, injured, and killed) was recorded.

4.3 Effects of Entrainment

Evaluation of the potential fish population and production effects of entrainment at the Project diversions was determined using:

- Project operations data (hydrology, percent of flow diverted, and the timing of duration of diversions);
- Fish population data obtained from the AQ 2 – Fish Population TSR (SCE 2019);
- Entrainment and mortality information from literature;
- Characterization of fish survival at the powerhouse turbines using literature-based survival estimates; and
- Estimates of fish entrainment via direct entrainment sampling in this study and indirect estimates.

5 STUDY RESULTS

The results for the (1) Project facilities characterization; (2) direct entrainment sampling; and (3) effects of entrainment are provided below. Each Project diversion facility and entrainment sampling location is shown on Map AQ 9-1.

5.1 Project Facilities Characterization

5.1.1 Kaweah No. 1 Development

The Kaweah No. 1 Diversion is located on the East Fork Kaweah River just upstream of the bridge crossing on Mineral King Road (approximately river mile 4.75). An aerial view of the Kaweah No. 1 Flowline Intake with key infrastructure labeled is shown in Figure AQ 9-1. The flowline intake is upstream of Kaweah No. 1 Diversion Dam. The diversion dam is a 6-foot high overflow concrete gravity dam, with a crest length of 20 feet at an elevation of 2,583 feet above mean sea level (msl). The flowline intake is 6 feet high, 3 feet wide and coarsely screened (trash rack). The trash rack is oriented parallel to flow in the East Fork Kaweah River and the intake of water is perpendicular to the flow. A small, L-shaped concrete wing wall shields the intake from upstream flow (Figure AQ 9-2). The intake flows into unlined tunnel controlled by a manually operated slide gate (Figures AQ 9-1, AQ 9-2, and AQ 9-3). The tunnel extends approximately 50 feet and empties into a sandbox (sediment trap) at the downstream end (Figure AQ 9-1). Flow enters the flowline from a slide gate located in the sandbox (Figure AQ 9-1) and passes through a fishwheel located in the flume (Figure AQ 9-4). Flow is routed along the 30,723-foot long flowline to the Kaweah No. 1 Forebay Tank (Figure AQ 9-5), which is a 24-foot diameter steel tank with a capacity of 0.18 acre-feet (ac-ft), and exits via the Kaweah No. 1 Penstock. The penstock is 3,340-foot long buried steel pipe varying in diameter from 48-19 inches that leads to the Kaweah No. 1 Powerhouse. The powerhouse contains a single-jet, single-overhung impulse turbine with an installed capacity of 2.25 megawatts (MW). The maximum estimated hydraulic capacity of the Kaweah No. 1 Powerhouse is 24 cubic feet per second (cfs). From the powerhouse, a short tailrace canal returns the diverted water back into the Kaweah River.

The Kaweah No. 1 Flowline diverts up to 24 cfs (typically less) from the East Fork Kaweah River. To maintain sufficient head pressure to meet consumptive water delivery contractual obligations along the flowline, SCE must maintain a minimum continuous flow of 1 cfs in the flowline. Hydrologic statistics for Kaweah No. 1 Flowline are shown in Tables AQ 9-2a and AQ 9-2b. Calculated velocity fields at the Kaweah No.1 Flowline Intake range from 1.60 feet/second at 5 feet of depth at the intake up to 8.00 feet/second at 1 foot of depth at the intake (Table AQ 9-3).

The perpendicular orientation of the intake to the river flow direction (trash rack parallel to the flow) likely helps reduce fish entrainment into the tunnel/sandbox and ultimately into the flowline (i.e., only fish moving along the margin of the channel could be entrained). Incidental observations by maintenance workers and field biologists suggest the number of fish entrained is low. The flowline just downstream of the sandbox has a rotary screen wheel (Figure AQ 9-4), which would provide an impediment to large fish entering the flowline. Any fish entering the flowline could stay in the 30,723 feet long flowline or enter the forebay tank for the powerhouse (Figure AQ 9-5). Because the Kaweah No. 1 Powerhouse is an impulse turbine with high head, likely fish entering the powerhouse from the forebay would not survive (e.g., nearly 100% mortality).

5.1.2 Kaweah No. 2 Development

The Kaweah No. 2 Diversion is located on the Kaweah River immediately downstream of the Sequoia National Park (SNP) boundary. An aerial view of the Kaweah No. 2 Flowline Intake with key infrastructure labeled is shown in Figure AQ 9-6. The flowline intake is upstream of a diversion dam. The diversion dam is a 7-foot high masonry overflow gravity dam, with an overall crest length of 161 feet at an elevation of 1,365 feet above msl. An intake vertical rotary screen (trash screen) is parallel to the flow in the Kaweah

River (intake of water is perpendicular to the flow) and a wing wall upstream of the intake forms a quiescent alcove leading to the trash screen that protects the intake (Figures AQ 9-7 and AQ 9-8). The concrete intake structure discharges into a 54-inch diameter by 42-foot long steel pipe, through a 54-inch square manually operated wooden slide gate and into the Kaweah No. 2 Flowline (87 cfs capacity). The concrete intake also feeds a minimum instream flow pipe that releases into the Kaweah River before the flow enters the Kaweah No. 2 Flowline and downstream of the Kaweah No. 2 Diversion Dam. The Kaweah No. 2 Flowline has a steel mesh fishwheel near the upstream end of the flume (Figure AQ 9-9). The flowline is 21,607 feet in length, including 16,738 feet of concrete ditch; 3,822 feet of steel flume comprised of 19 segments; and 1,047 feet of 50-inch diameter steel pipe. The Kaweah No. 2 Forebay, located at the end of the flowline, is an enlargement of the Kaweah No. 2 Flowline. The forebay extends for a distance of 180 feet and has a cross section 13-feet wide by 14-feet deep and a capacity of 0.75 ac-ft. From the forebay, flow is conveyed to the Kaweah No. 2 Powerhouse through the Kaweah No. 2 Penstock. The penstock is a 1,012-foot long buried steel pipe varying in diameter from 60-34 inches leading to the Kaweah No. 2 Powerhouse. The powerhouse contains a single Francis-type turbine and electrical generator with an installed generating capacity of 1.8 MW. The maximum estimated hydraulic capacity of the Kaweah No. 2 Powerhouse is 82 cfs. From the powerhouse, a 0.3-mile long tailrace canal returns the diverted water to the Kaweah River.

The Kaweah No. 2 Flowline (Kaweah River) can divert up to 87 cfs. To maintain sufficient head pressure to meet consumptive water delivery contractual obligations along the flowline, SCE must maintain a minimum continuous flow of 3 cfs in the flowline. Hydrologic statistics for Kaweah No. 2 Flowline are shown in Tables AQ 9-2a and AQ 9-2b. Calculated velocity fields at the Kaweah No. 2 Flowline Intake range from 1.45 feet/second at 5 feet of depth at the intake up to 7.3 feet/second at 1 foot of depth at the intake (Table AQ 9-3).

The perpendicular orientation of the intake to the river flow direction likely helps reduce fish entrainment (i.e., only fish moving along the margin of the channel could be entrained). Incidental observations by maintenance workers and field biologists suggest the number of fish entrained is low. Direct entrainment sampling results are presented in Section 5.2. The flowline near the top of has a rotary screen fishwheel (Figure AQ 9-9), which would provide some impediment to large fish entering the flowline. Any fish entering the flowline could stay in the 21,607 feet of flowline or enter the forebay for the powerhouse (Figure AQ 9-10) until the flowline and/or forebay are periodically “drained.” Typically, a small amount of flow remains in the flowline and forebay due to water rights deliveries and fish may not experience complete dewatering very frequently. When the flowline and forebay are “drained” (not diverting water for power generation), fish could enter the discharge drains from the forebay/flume into natural channels and then the Kaweah River (very steep, potentially some fish could survive), remain in the forebay, or enter the penstock and powerhouse. There are no incidental observations of fish stranding in the forebay when it is lowered (SCE maintenance staff, pers. observ.).

Because the Kaweah No. 2 Powerhouse is a Francis turbine with lower head, likely a moderate to high percentage of fish entering the powerhouse would survive. Francis-type turbines typically have average survival rates of 67-90% for fish <250 millimeter (mm) passing through them (Winchell et al. 2000). Survival depends on the size of the fish, the peripheral runner velocity, and blade and or wicket spacing/clearance. Translocation of fish from the diversion, into the flowline/forebay, into the powerhouse, and back into the Kaweah River below the powerhouse would likely be associated with high to moderate survival.

5.1.1 Kaweah No. 3 Development

The diversions for the Kaweah No. 3 Flowline are within the SNP on the Marble Fork and Middle Fork Kaweah rivers and are not part of the FERC project. They are operated as part of a National Park Service Special Use Permit (Permit No. PWR-SEKI-6000-2016-015) issued to SCE. The short segment of the Kaweah No. 3 Flowline outside of the SNP boundary that is under FERC jurisdiction consists of a

2,975-foot long concrete box flume that conveys water to the Kaweah No. 3 Forebay (Figure AQ 9-11). The flowline has a maximum diversion capacity of approximately 97 cfs. The Kaweah No. 3 Forebay is an embankment concrete forebay with a capacity of approximately 11 ac-ft. At the downstream end of the forebay, water is released into a 42-inch steel pipe which connects to the Kaweah No. 3 Penstock. In addition, a low-level outlet is used to drain the forebay to conduct sediment management and Project maintenance activities. Water released from the low-level outlet enters a short concrete chute. The chute discharges into an adjacent natural channel that flows approximately 0.5 mile into the Kaweah River (downstream of the Kaweah No. 2 Diversion Dam). The Kaweah No. 3 Penstock is a 3,151-foot long buried steel pipe varying in diameter from 42-36 inches. The penstock conveys water to the Kaweah No. 3 Powerhouse. The Kaweah No. 3 Powerhouse contains two single-jet, single-overhung impulse turbines with a combined installed generating capacity of 4.8 MW. The maximum estimated hydraulic capacity of the Kaweah No. 3 Powerhouse is 92 cfs. From the powerhouse, a short tailrace canal returns the diverted water to the Kaweah River.

Hydrologic statistics for Kaweah River, Kaweah No. 3 Flowline, and Kaweah No. 3 Powerhouse are shown in Tables AQ 9-2a and AQ 9-2b.

Any fish entering the flowline could stay in the flowline or enter the forebay for the powerhouse (Figure AQ 9-11) until the flowline and/or the forebay are periodically drained. When the forebay is drained, fish could enter the forebay release into the natural channels and the Kaweah River (very steep, potentially some fish could survive), remain in the forebay and be dewatered, or enter the penstock and powerhouse. Incidental observations by maintenance workers during maintenance outages and draining of the Kaweah No. 3 Forebay, suggest the number is low. Because the Kaweah No. 3 Powerhouse is an impulse turbine with high head (750 feet), likely fish entering the powerhouse would not survive (nearly 100% mortality).

5.2 Direct Entrainment Sampling

5.2.1 Kaweah No. 1 Flowline

Direct entrainment sampling occurred at the top of the Kaweah No. 1 Flowline for one day on May 14, 2019, however, due to conflicts with the landowner who has a home on the other side of the river near the sampling location, the sampling was cancelled.

The safe sampling flow in the flowline for fyke netting was determined by field biologists and SCE staff to be 7-8 cfs, based on experimenting with the fyke net in the flume, adjusting flows, and observing the flume freeboard remaining upstream of the net. The Kaweah No. 1 Flowline was sampled for adult and juvenile fish using a custom fyke trap (fit to the shape of the flowline) at the entrance of the Kaweah No. 1 Flowline just downstream of the sandbox (Figures AQ 9-1 and AQ 9-12). Drift net sampling with a 12-inch by 17-inch rectangular opening occurred immediately downstream where the diverted water was released from the flume back to the East Fork Kaweah River (Figures AQ 9-1 and AQ 9-13). Flow at the fyke net was 7.2 cfs and flow at the drift net was 6.2 cfs, 1 cfs less than the total flume diversion due to consumptive water deliveries (Tables AQ 9-4 and AQ 9-5). The fyke net sampled 100% of the flume flow and the drift net was able to capture approximately 38% of the flow. The sampling for two 4-hour time windows during the day and a 0.8-hour time window at night before the sampling was discontinued, resulted in no fish (adult, juvenile, or fry) being captured (Tables AQ 9-4 and AQ 9-5). In addition, no fish were visually observed in the sandbox or flume.

Additional sampling of the Kaweah No. 1 Flowline will occur following repair of the flowline damaged in a landslide in July 2018 (repair is currently projected for summer 2020) and within 18 months of issuance of the new license (Table AQ 9-1) (see Application for New License, Exhibit E, Section 4, Appendix 4-A Entrainment Study Measure). A new sampling location, likely immediately upstream of the Kaweah No. 1 Forebay, will be used for the sampling (Figure AQ 9-5).

5.2.2 Kaweah No. 2 Flowline

Kaweah No. 2 Flowline was sampled for adult and juvenile fish using a modified fyke trap and three drift nets approximately 800 feet downstream of the Kaweah No. 2 Intake (Figure AQ 9-14). The custom built fyke net sampled 100% of the flow (Figure AQ 9-15). Three 6-inch diameter opening drift nets sampled 20 to 24% of the flow (Figure AQ 9-16). The safe sampling flow in the flowline was determined by fish biologist sampling crew and SCE staff to be approximately 38 cfs based on experimenting with the fyke net in the flume, adjusting flows, and observing the flume freeboard remaining upstream of the net. Sampling occurred May 7-9, 2019 (late spring) and July 9-11, 2019 (summer). The sampling for three days each sampling period (six days total), including two 4-hour time windows each day and one 4-hour hour time window each night, resulted in the capture of one juvenile fish (Sacramento pikeminnow, 35 mm total length [TL]) (Tables AQ 9-5 and AQ 9-6; Figure AQ 9-17). During each day of entrainment sampling (six days total), staff walked the approximately 800-foot section of flowline upstream of the modified fyke trap location to visually observe if fish were present in the flowline. No fish were observed.

Completion of the Kaweah No. 2 Flowline sampling (winter and early spring samples) will occur by April 2020 (see Application for New License, Exhibit E, Section 4, Appendix 4-A Entrainment Study Measure).

5.2.3 Kaweah No. 3 Flowline

Due to the risk associated with fyke netting the Kaweah No. 3 Flowline, only drift net samples were collected to sample for fry entrainment in the flowline (Figure AQ 9 -11) per the revised AQ-9 Entrainment TSP. The flowline was sampled for fry on May 21-23, 2019, (late spring) and July 23-25, 2019, (summer) at 58-90 cfs using three drift nets with 6-inch diameter openings that sampled 8 to 12% of the flow (Table AQ 9-5; Figure AQ 9-18). During the six days total of entrainment sampling, including two 4-hour time windows each day and one 4-hour hour time window each night, no fish were captured (Table AQ 9-5). During each day of the six days of entrainment sampling, staff walked an approximate 1,000-foot section of flowline upstream of the Kaweah No. 3 Forebay location to observe if fish were present in the flowline. No fish were observed.

Based on consultation with resource agencies on December 3 and December 10, 2019, drift net sampling in the Kaweah No. 3 Flowline was deemed complete at this time and the need for any additional drift net sampling in the Kaweah No. 3 Flowline will be determined based on interpretation of drift net sampling results from the Kaweah No. 2 Flowline (see Application for New License, Exhibit E, Section 4, Appendix 4-A Entrainment Study Measure).

5.3 Effects of Entrainment

5.3.1 Fish Population

5.3.1.1 *Percent of Flow Diverted and Timing*

Percent of flow diverted for the Kaweah No. 1 and Kaweah No. 2 flowlines ranges from 14-43%, on average, July through March and is typically less, 5-15%, April through June (Table AQ 9-2b). The diversion for Kaweah No. 3 Flowline (outside the FERC boundary) is likely similar to Kaweah No. 2 Flowline.

5.3.1.2 *Fish Population Data*

Based on the data collected in the AQ 2 – Fish Population TSP, Sacramento sucker, Sacramento pikeminnow, and hardhead (including young-of-year [YOY] mixed minnows), were the dominant fish species in the study reaches (Table AQ 9-6) (SCE 2019). Rainbow trout numbers in the reaches were relatively low, ranging from 0-707 fish/mile (0-25.6 lbs/mile), with the highest numbers in the upper East Fork Kaweah River where the water temperature was cooler (Table AQ 9-7) (SCE 2019).

5.3.1.3 Entrainment Survival Literature Review

Powerhouses

The potential survival rate of fish passing through the Project powerhouses are as follows:

- Kaweah No. 1 and No. 3 powerhouses with impulse turbines – Extremely low Survival (approximately 0%).
- Kaweah No. 2 Powerhouse with a Francis turbine – Moderate to high survival (67-90% for fish <250 mm) (Winchell et al., 2000).

Historical Studies and Literature

Direct entrainment sampling of Sierra Nevada trout streams, Duncan Creek (Middle Fork American River tributary) and West Panther Creek (Mokelumne River tributary), and indirect movement studies of resident trout streams in various locations (Gowen and Fausch 1996; Jenkins et al. 1999; Hilderbrand and Kershner 2000; Graf 2007) were used by Placer County Water Agency (PCWA) for the Middle Fork Project relicensing (PCWA 2011) and resource agencies (California Department of Fish and Wildlife, State Water Board, U.S. Forest Service) to quantify entrainment at Project diversions. The Duncan Creek study included Passive Integrated Responder (PIT) tagging approximately 1,000 fish in the two miles upstream of the Duncan Creek Diversion and monitoring entrainment over an entire diversion year and the West Panther Creek study included sampling 100% of the diverted flow with an incline plane fish trap. Details on both the direct sampling and the indirect movement study entrainment approaches are available in PCWA (2011).

Entrainment estimates ranged from 0.9 to 4.2% of the population in the first two miles upstream of the diversions for the literature based movement methods and from 1.0 to 2.3% of the population in the first two miles upstream of the diversions for the direct entrainment sampling methods. Because of the fish populations upstream of the Kaweah No. 1 Flowline (East Fork Kaweah River) and the Kaweah No. 3 Flowline are predominately trout, these entrainment estimates (PCWA 2011) are likely applicable to the Kaweah No. 1 and 2 flowlines.

5.3.1.4 Direct and Indirect Estimates of Entrainment

Direct sampling to date at the Kaweah No. 2 Flowline and Kaweah No. 1 Flowline, indicate little to no entrainment (one fish captured). Incidental observation by biologists and SCE maintenance workers also indicate very low entrainment potential.

Indirect estimates of entrainment from Sierra Nevada trout streams based on empirical entrainment or literature based movement studies (PCWA 2011) indicate relatively low entrainment (0.9 to 4.2% of the fish in the two miles of river upstream of the diversion annually). For the trout stream flowlines, Kaweah No. 1 and Kaweah No. 3 flowlines, this range of entrainment would result in less than approximately 50 fish annually, or potentially much less, at each flowline.

Based on the available data it appears entrainment at the Kaweah Nos. 1, 2, and 3 flowlines is very low and would have very limited effect on the stream fish populations.

6 LITERATURE CITED

FERC (Federal Energy Regulatory Commission). 2017. Study Plan Determination for the Kaweah Hydroelectric Project. October 24.

Gowen, C. and K.D. Fausch. 1996. Mobile brook trout in two high-elevation Colorado streams: re-evaluating the concept of restricted movement. *Can. J Fish. Aquat. Sci.* 53: 1370-1381.

- Graf, P. 2007. The movement behaviors of a non-native trout in the Truckee River, CA. Unpublished Master's Thesis. University of Nevada, Reno.
- Hilderbrand, R.H. and J.L. Kershner. 2000. Movement Patterns of Stream-Resident Cutthroat Trout in Beaver Creek, Idaho-Utah. Transactions of the American Fisheries Society 129:1160-1170. Hunt RL. 1965. Dispersal of Wild Brook Trout During Their First Summer of Life. Transactions of the American Fisheries Society: Vol. 94, No. 2 pp. 186-188.
- Jenkins, Jr, T.M., S. Diehl, K.W. Kratz, and S. D. Cooper. 1999. Effects of Population Density on Individual Growth of Brown Trout In Streams. Ecology, 80(3)941-956.
- PCWA (Placer County Water Agency). 2011. Application for New License. Middle Fork American River Project (FERC Project No. 2079). AQ 7 – Entrainment Technical Study Report (2010). Exhibit E, Volume 3, Supporting Document B. Filed with FERC February 23, 2011.
- SCE (Southern California Edison Company). 2017a. Kaweah Project, Revised Study Plan. Filed with FERC on September 19.
- SCE. 2017b. Kaweah Project, Proposed Study Plan. Filed with FERC on May 24.
- SCE. 2019. Kaweah Project, AQ – 2 Fish Population Technical Study Report. December.
- Winchell, F., S. Amaral and D. Dixon. 2000. Hydroelectric Turbine Entrainment and Survival Database: An Alternative to Field Studies. Paper presented at Hydrovision 2000.

This Page Intentionally Left Blank

TABLES

This Page Intentionally Left Blank

Table AQ 9-1. Proposed entrainment field schedule (also see Application for New License Section 4, Appendix 4-A Entrainment Study Measure).

Location	Representative Time Periods	Sampling Dates	Sampling Type	
			Drift Netting	Fyke Trapping
Kaweah No. 1 Flowline	January/February within 18 months of license issuance*	TBD	Pending	Pending
	March/April within 18 months of license issuance*	TBD	Pending	Pending
	May/June within 18 months of license issuance*	TBD	Pending	Pending
	July within 18 months of license issuance*	TBD	Pending	Pending
Kaweah No. 2 Flowline	May/June 2019	May 7-9, 2019	Completed	Completed
	July 2019	July 9-11, 2019	Completed	Completed
	January/February 2020	TBD	Pending	Pending
	March/April 2020	TBD	Pending	Pending
Kaweah No. 3 Flowline	May/June 2019	May 21-23, 2019	Completed	NA**
	July 2019	July 23-25, 2019	Completed	NA**
	January/February 2020	NA	Sampling was deemed complete at the present time***	NA**
	March/April 2020	NA	Sampling was deemed complete at the present time***	NA**

* Monitoring will be completed within 18 months of license issuance consistent with the Application for New License Section 4, Appendix 4-A Entrainment Study Measure.

** Due to high risk at the Kaweah No. 3 Flowline, the revised study plan proposed to use entrainment monitoring in the Kaweah No. 1 and No. 2 flowlines to approximate entrainment in Kaweah No. 3 Flowline. The revised study plan allowed for additional entrainment sampling based on consultation with agency biologists/staff.

*** Based on collaboration between SCE and key resource agencies with respect to entrainment sampling (CDFW and the State Water Board) on December 3 and December 10, 2019, drift net sampling in the Kaweah No. 3 Flowline was deemed complete at this time and the need for any additional drift net sampling in the Kaweah No. 3 Flowline will be determined based on interpretation of drift net sampling results from the Kaweah No. 2 Flowline (see Application for New License Section 4, Appendix 4-A Entrainment Study Measure).

NA = Not Applicable

TBD = To Be Determined

Table AQ 9-2a. Flow statistics for stream gages and flowlines associated with the Kaweah Project for the available period of record (1994-2018).

Month	Daily Exceedance Flows by Month (cfs)					Maximum, Minimum, and Average Daily Flows (cfs)		
	10%	20%	50%	80%	90%	Max	Min	Average
Calculated Unimpaired Flow Upstream of Kaweah No. 1 Diversion¹ (WY 1994-2018)								
Oct	36.9	26	16.4	10.2	8.9	1061.0	6.3	22.1
Nov	41.9	32.1	21.1	14.8	10.8	1933.8	8.5	31.8
Dec	58.6	42.9	27	19.1	15.2	1220.0	7.5	42.7
Jan	137.5	80	39.7	23.1	17.2	4424.8	8.5	82.1
Feb	174.8	94	54.2	36	24.7	1260.0	10.2	83.5
Mar	229.6	178	97.8	53.9	41.7	1144.4	22.9	119.1
Apr	350	303.8	190.7	117.9	84.7	1246.7	31.0	208.9
May	624.2	477.2	338	199.8	152.8	1300.0	36.0	372.8
Jun	922.9	539.2	197.2	70.2	45.9	1503.7	19.0	343.7
Jul	355.1	197.4	52.3	23.6	19.2	1341.5	11.2	139.6
Aug	78.3	51.0	19.4	12.1	10.3	333.0	6.6	37.5
Sep	40.0	30.2	16.3	9.4	8.1	111.5	6.0	21.0
East Fork Kaweah River downstream Kaweah No. 1 Diversion (USGS Gage No. 11208730) (1993-2018)								
Oct	22	16.9	9.8	6.9	6	4420	5.2	15.3
Nov	26.3	19	10.4	7.3	6.4	1930	2.7	21.8
Dec	45	28	13	7.4	6.5	1220	3.1	30.4
Jan	126.6	61.2	23	9	7.4	4420	5.2	68.1
Feb	156.9	78.9	35	17	10.9	1260	5.2	66.9
Mar	214	161.1	79.5	34	26	1140	12	102.1
Apr	338	288	170.2	97.3	64.3	1240	13	190.8
May	610.1	458.7	317.4	181.8	132.4	1281	18	354.4
Jun	910.3	519.8	181.3	52.4	30	1500	11.9	326.5
Jul	338.6	181.3	33.2	13.8	12	1319.2	10.9	124.9
Aug	61	32	9.9	6.9	6.3	311	5	25.9
Sep	21	15	8.4	6.3	6.1	87.7	4.8	11.8
Kaweah No. 1 Flowline (USGS Gage No. 11208720 and SCE Gage 202) (WY 1994-2002 and 2002-2018)								
Oct	18.9	13.8	4	0.8	0.2	26	0	6.8
Nov	19	16.6	11	1	0.7	23.3	0	10
Dec	21.2	19.6	13	4.7	0.5	24	0	12.3
Jan	22	21.2	16	6.2	0.8	24	0	14
Feb	22.3	21.5	19	13	5.7	24	0	16.6
Mar	23	22	19	13	4.3	25	0	16.9

Month	Daily Exceedance Flows by Month (cfs)					Maximum, Minimum, and Average Daily Flows (cfs)		
	10%	20%	50%	80%	90%	Max	Min	Average
Apr	23.5	22.9	19	16	8.1	24.4	0	18.1
May	23.8	23	19	16	13.4	24.7	0	18.4
Jun	23.6	23	19.1	12	3.3	25.1	0	17.2
Jul	22.8	21	17	7.6	0.7	26	0	14.7
Aug	21	20	11	2.5	0.7	24	0	11.6
Sep	20.7	18.3	6.8	0.6	0.4	24	0	9.1
Flow to Kaweah No. 1 Powerhouse (USGS Gage No. 11208800) (WY 2002-2018)								
Oct	13	5.9	0	0	0	19	0	3
Nov	18	14	0	0	0	21	0	6.2
Dec	18	14	10	0	0	21	0	7.9
Jan	20	19	15	0	0	22	0	11.8
Feb	20	20	18	8.7	2	22	0	15.2
Mar	20	20	18	5	0	22	0	14
Apr	21	20	18	14	0	22	0	15.8
May	20	20	18	15	12	22	0	16.6
Jun	21	20	18	11	0	22	0	15
Jul	19	18	14	0	0	22	0	11.5
Aug	19	18	7.5	0	0	21	0	8.8
Sep	18	16	0	0	0	21	0	6
Calculated Unimpaired Flow Upstream of Kaweah No. 2 Diversion² (WY 1994-2018)								
Oct	142	60.8	32.7	19.9	18.3	260.4	16.4	51.4
Nov	189.9	96.1	55.3	33.4	24	377.4	20.6	80.8
Dec	329	135.8	90.3	49.7	26.8	409.6	24.2	109.8
Jan	275.2	245	136.8	77.8	52	1292.7	18.9	197
Feb	436.4	234.2	184.9	102.6	91.2	514.1	57.5	199.3
Mar	458.4	417.8	291.9	188.1	159.7	600.2	109.6	307
Apr	741.8	632.5	491.4	339.9	306	771.5	273.5	502.1
May	1213.9	1052.5	905	486.7	355.9	1413.8	345.6	832
Jun	1612.1	1442.5	555.2	179.6	116.8	2075	114	726.2
Jul	1188.5	513.6	133.9	50.8	31.1	1647.5	24.6	331
Aug	320.3	93.7	37	22.2	18.6	334.2	17.9	81.4
Sep	92	44	24.5	16.5	14.6	161.8	11.3	36.9

Month	Daily Exceedance Flows by Month (cfs)					Maximum, Minimum, and Average Daily Flows (cfs)		
	10%	20%	50%	80%	90%	Max	Min	Average
Kaweah River Downstream Kaweah No. 2 Diversion (USGS Gage No. 11208600) (WY 1994-2018)								
Oct	50	28	16	12	10	3910	5.6	32.9
Nov	65	31.2	18	12.1	11	5300	5.6	43.8
Dec	112.2	60.4	19	12.9	9.4	2830	5.5	60.5
Jan	323.2	147.2	49	21	15.3	9800	10	151.3
Feb	326	200	80.3	30	24.4	2550	11	158
Mar	474.6	337.6	188	95	59	1760	24	240.8
Apr	780.7	606.9	374.5	219.6	151.6	2680	34	433.3
May	1290	1070	668	350	238.8	2500	40	725.6
Jun	1620.6	1159.3	355.5	95	39.9	2590	29.8	622.9
Jul	764.6	364.6	37	20	14	2440	11	246
Aug	97.4	37	22.4	16	12.6	602	9.5	47.4
Sep	25.3	18	13.7	11	8.5	322	5.8	19.1
Kaweah No. 2 Flowline (USGS Gage No. 11208570 + SCE Gage 204a) (1994-2002 and 2002-2018)								
Oct	35	22	4.4	2.1	1.6	97	0.3	13.1
Nov	74	58	21	2.5	1.6	89	0.7	29.2
Dec	78	70	40	14	3.6	91	0.8	41.4
Jan	82	79	52	13	2.6	90	0	47.2
Feb	84	82.4	74	40	5	90	1	63.1
Mar	87	85	79	67	30.4	92	0.1	70.8
Apr	87.5	85.5	81	70	63	96	0.2	75.8
May	87	85.5	81	72	69	95	12	78.1
Jun	87	85	79	68	56	94	6.9	73.9
Jul	86	83	69	28	8.9	97	0.7	56.8
Aug	82	70	9.7	2.6	2.1	90	0	27.7
Sep	53	26.9	4.8	2.2	1.8	90	0	15.8
Kaweah No. 2 Powerhouse Tailrace Channel (USGS Gage No. 11208818) (WY 2002-2018)								
Oct	30	0	0	0	0	78	0	7.3
Nov	72	63	13	0	0	80	0	25.2
Dec	74	62	34	0	0	79	0	33.8
Jan	77	76	41	0	0	79	0	41.8
Feb	78	78	71	24	0	83	0	55.1
Mar	80	79	76	53	0	81	0	61.9
Apr	80	79	75	69	61	81	0	70.5

Month	Daily Exceedance Flows by Month (cfs)					Maximum, Minimum, and Average Daily Flows (cfs)		
	10%	20%	50%	80%	90%	Max	Min	Average
May	79	79	74	68	66	80	0	71.8
Jun	79	79	72	62	35.9	80	0	65.9
Jul	78	77	51.5	0	0	81	0	45.7
Aug	72	63	0	0	0	78	0	20.3
Sep	31	22	0	0	0	70	0	8.1
Flow to Kaweah No. 3 Powerhouse (USGS Gage 11208565) (WY 2002-2018)								
Oct	24	15	0	0	0	84	0	7.9
Nov	66.1	44	14.5	0	0	86	0	21.4
Dec	78	65	29.5	0	0	91	0	32.7
Jan	86	77	25	0	0	92	0	34.9
Feb	89	87	51.5	0	0	92	0	47.4
Mar	91	91	85	48	34	92	0	69.8
Apr	91	90.2	88	47	0	92	0	70.6
May	92	90	88	45	0	92	0	71.4
Jun	92	90	86	37.8	1.4	92	0	67
Jul	91	88	36	0	0	92	0	43.4
Aug	69.5	45	0	0	0	88	0	18.1
Sep	27	9.2	0	0	0	68	0	6

¹ 1994-2002: Sum of East Fork Kaweah River downstream of the Kaweah No. 1 Diversion (11208730 [SCE 201]) and the Kaweah No. 1 Flowline (USGS 11208720 [SCE 202]), 2002-2018: Sum of East Fork Kaweah River downstream of the Kaweah No. 1 Diversion (11208730 [SCE 201]) and the Kaweah No. 1 Flowline (USGS 11208720 [SCE 202]).

² 1994-2002: Sum of Kaweah No. 2 Flowline (USGS 11208570 [SCE 204a]), the main Kaweah River downstream of the Kaweah No. 2 Diversion (USGS 11208600 [SCE 203]), and the discharge of the Kaweah No. 3 Powerhouse (Sum of SCE 210 & SCE 208 gages). 2002-2018: Sum of Kaweah No. 2 Flowline (USGS 11208570 [SCE 204a]), the main Kaweah River downstream of the Kaweah No. 2 Diversion (USGS 11208600 [SCE 203]), and the discharge of the Kaweah No. 3 Powerhouse (SCE 206a).

Table AQ 9-2b. Percent of flow diverted at each flowline for the period of record (1994-2018).

Month	Daily Exceedance Flows by Month (cfs)					Maximum, Minimum, and Average Daily Flows (cfs)		
	10%	20%	50%	80%	90%	Max	Min	Average
Kaweah No. 1 Flowline percent of Unimpaired Flow Upstream of Diversion (USGS Gage No. 11208720 and SCE Gage 202) (WY 1994-2002 and 2002-2018)								
Oct	51	53	24	8	2	2	0	31
Nov	45	52	52	7	6	1	0	31
Dec	36	46	48	25	3	2	0	29
Jan	16	27	40	27	5	1	0	17
Feb	13	23	35	36	23	2	0	20
Mar	10	12	19	24	10	2	0	14
Apr	7	8	10	14	10	2	0	9
May	4	5	6	8	9	2	0	5
Jun	3	4	10	17	7	2	0	5
Jul	6	11	33	32	4	2	0	11
Aug	27	39	57	21	7	7	0	31
Sep	52	61	42	6	5	22	0	43
Kaweah No. 2 Flowline percent of Unimpaired Flow Upstream of Diversion (USGS Gage No. 11208570 + SCE Gage 204a) (1994-2002 and 2002-2018)								
Oct	25	36	13	11	9	37	2	25
Nov	39	60	38	7	7	24	3	36
Dec	24	52	44	28	13	22	3	38
Jan	30	32	38	17	5	7	0	24
Feb	19	35	40	39	5	18	2	32
Mar	19	20	27	36	19	15	0	23
Apr	12	14	16	21	21	12	0	15
May	7	8	9	15	19	7	3	9
Jun	5	6	14	38	48	5	6	10
Jul	7	16	52	55	29	6	3	17
Aug	26	75	26	12	11	27	0	34
Sep	58	61	20	13	12	56	0	43

Table AQ 9-3. Estimated maximum intake velocity at the Kaweah No. 1 and Kaweah No. 2 Flowline intake screens.

Kaweah No. 1 ¹ Flowline Intake		Kaweah No. 2 ² Flowline Intake	
Intake Depth (ft.)	Intake Velocity (ft./s)	Intake Depth (ft.)	Intake Velocity (ft./s)
5.0	1.60	5.0	1.45
4.8	1.68	4.8	1.53
4.5	1.78	4.5	1.61
4.3	1.88	4.3	1.71
4.0	2.00	4.0	1.81
3.8	2.13	3.8	1.93
3.5	2.29	3.5	2.07
3.3	2.46	3.3	2.23
3.0	2.67	3.0	2.42
2.8	2.91	2.8	2.64
2.5	3.20	2.5	2.90
2.3	3.56	2.3	3.22
2.0	4.00	2.0	3.63
1.8	4.57	1.8	4.14
1.5	5.33	1.5	4.83
1.3	6.40	1.3	5.80
1.0	8.00	1.0	7.25

¹ The width was set to 3 ft and the flow was set to 24 cfs for this calculation.

² The width was set to 12 ft and the flow was set to 87 cfs for this calculation.

Table AQ 9-4. Summary of fyke net entrainment sampling results in the Kaweah Project flowlines in 2019. Appendix A contains each individual sampling period results.

Flowline	Sampling Date	Time Window ¹	Time Deployed (hours)	Water Volume Sampled (ft ³)	Water Volume through Flowline (ft ³)	Average Flowline Flow (cfs)	Number of Fish Captured	Percent of Flow Sampled	Number of Fish / Hour Captured	Estimated Number of Fish / Hour Entrained	Estimated Number of Fish / Hour / cfs Entrained
K1	May 14, 2019	8:00am–1:00pm	4.0	102960.0	102960.0	7.3	0	100	0	0	0
		3:00pm–8:00pm	4.0	104040.0	104040.0	7.3	0	100	0	0	0
		10:00pm–3:00am	0.8	19507.5	19507.5	7.5	0	100	0	0	0
K2	May 7-9, 2019 ³	8:00am–1:00pm	12.1	1596747.9	1596747.9	36.0	0	100	0	0	0
		3:00pm–8:00pm	11.9	1318029.5	1318029.5	37.0	0	100	0	0	0
		10:00pm–3:00am	11.2	1525650.7	1525650.7	38.0	1 ²	100	0.1	0.1	0.002
	July 9-11, 2019	8:00am–1:00pm	12.0	1560589.9	1560589.9	36.1	0	100	0	0	0
		3:00pm–8:00pm	12.0	1524019.8	1524019.8	35.3	0	100	0	0	0
		10:00pm–3:00am	12.3	1640788.1	1640788.1	37.2	0	100	0	0	0

¹ Four hours were sampled within each 5-hour time window on each day sampled.

² Fish captured was a 35 mm juvenile Sacramento pikeminnow.

³ Due to a rainstorm that put debris in the flowline the fyke net had to be removed early on the last sampling day (leaves/debris were clogging the net and causing dangerous sampling conditions).

Table AQ 9-5. Summary of drift net entrainment sampling results in the Kaweah Project flowlines in 2019. Appendix A contains each individual sampling period results.

Flowline	Sampling Date	Time Window ¹	Time Deployed (hours)	Water Volume Sampled (ft ³)	Water Volume through Flowline (ft ³)	Average Flowline Flow (cfs)	Number of Fish Captured	Percent of Flow Sampled	Number of Fish / Hour Captured	Estimated Number of Fish / Hour Entrained	Estimated Number of Fish / Hour / cfs Entrained
K1 ²	May 14, 2019	8:00am–1:00pm	4.0	33787.4	93168.0	6.6	0	36.3	0	0	0
		3:00pm–8:00pm	4.0	34594.9	94248.0	6.6	0	36.7	0	0	0
		10:00pm–3:00am	0.5	2624.4	11616.0	6.9	0	22.6	0	0	0
K2	May 7-9, 2019	8:00am–1:00pm	12.2	374093.1	1629690.1	36.0	0	23.0	0	0	0
		3:00pm–8:00pm	12.0	340061.1	1595297.6	37.0	0	21.3	0	0	0
		10:00pm–3:00am	11.7	381606.9	1596387.6	38.0	0	23.9	0	0	0
	July 9-11, 2019	8:00am–1:00pm	12.0	343897.9	1561649.4	36.1	0	22.0	0	0	0
		3:00pm–8:00pm	11.7	333660.7	1483564.3	35.3	0	22.5	0	0	0
		10:00pm–3:00am	11.4	318861.9	1531964.7	37.2	0	20.8	0	0	0
K3	May 21-23, 2019	8:00am–1:00pm	11.9	234314.5	2291053.6	58.3	0	10.2	0	0	0
		3:00pm–8:00pm	11.9	249899.3	2500680.7	58.5	0	10.0	0	0	0
		10:00pm–3:00am	11.6	262746.5	2442970.4	58.6	0	10.8	0	0	0
	July 23-25, 2019	8:00am–1:00pm	11.6	353384.1	3704029.6	88.1	0	9.5	0	0	0
		3:00pm–8:00pm	11.5	329907.4	3572486.2	87.0	0	9.2	0	0	0
		10:00pm–3:00am	11.3	299058.1	3663908.9	89.8	0	8.2	0	0	0

¹ Four hours were sampled within each 5-hour time window on each day sampled.

² Flows are approximately 1 cfs lower than the amount of water diverted into the flowline (Table AQ 9-2) because approximately 1 cfs for consumptive water deliveries was left in the flowline (i.e., bypassing the flume release into the river where the drift net sampling was being conducted).

Table AQ 9-6. Summary of reach density for all captured species excluding rainbow trout.

Study Reach	Species Reach Density (Fish per Mile)							Species Reach Density (Fish per Acre)						
	HH	SPM	MXD	SS	SC	CAR	SMB	HH	SPM	MXD	SS	SC	CAR	SMB
Kaweah River														
Kaweah River Upstream of Kaweah No. 3 Powerhouse (US PH3)	0	0	15389	5345	0	1993	0	0	0	1414	532	0	419	0
Kaweah River Downstream of Kaweah No. 3 Powerhouse and Upstream of the East Fork Kaweah River Confluence (DS PH3)	26	3400	12645	2079	0	850	0	5	652	2192	373	0	171	0
Kaweah River Downstream of East Fork Kaweah Confluence and Upstream of Kaweah No. 1 Powerhouse (US PH1)	6	104	0	684	0	0	611	1	14	0	140	0	0	95
Kaweah River Downstream of Kaweah No. 1 Powerhouse and Upstream of Kaweah No. 2 Powerhouse (US PH2)	19	2	5	237	54	0	622	2	0	1	42	10	0	109
Kaweah River Downstream of Kaweah No. 2 Powerhouse (DS PH2)	116	45	0	299	209	0	644	15	5	0	36	22	0	73
East Fork Kaweah River														
East Fork Kaweah River Upstream of the Kaweah No. 1 Diversion (EF US K1 Div)	0	0	0	1725	0	0	0	0	0	0	360	0	0	0
East Fork Kaweah River Downstream of the Kaweah No. 1 Diversion (EF DS K1 Div)	0	0	0	2486	0	13	0	0	0	0	627	0	3	0
East Fork Kaweah River Upstream of Confluence with Kaweah River (EF US Confl)	26	377	1341	255	0	409	137	4	107	217	86	0	120	33

- CAR = California Roach
- HH = Hardhead
- MXD = Unidentified Juvenile Mixed Minnow
- RBT = Rainbow Trout
- SC = Sculpin spp.
- SMB = Smallmouth Bass
- SPM = Sacramento Pikeminnow
- SS = Sacramento Sucker

Table AQ 9-7. Reach density and reach biomass of rainbow trout.

Study Reach	Reach Density (Adult; YOY)		Reach Biomass	
	Fish per Mile	Fish per Acre	Pounds per Mile	Pounds per Acre
Kaweah River				
Kaweah River Upstream of Kaweah No. 3 Powerhouse (US PH3)	102 (61; 41)	17 (10; 7)	11.3	1.8
Kaweah River Downstream of Kaweah No. 3 Powerhouse and Upstream of the East Fork Kaweah River Confluence (DS PH3)	142 (24; 118)	26 (4; 22)	0.8	0.2
Kaweah River Downstream of East Fork Kaweah Confluence and Upstream of Kaweah No. 1 Powerhouse (US PH1)	84 (42; 42)	19 (9.3; 9.3)	0.8	0.2
Kaweah River Downstream of Kaweah No. 1 Powerhouse and Upstream of Kaweah No. 2 Powerhouse (US PH2)	0	0	0.0	0.0
Kaweah River Downstream of Kaweah No. 2 Powerhouse (DS PH2)	0	0	0.0	0.0
East Fork Kaweah River				
East Fork Kaweah River Upstream of the Kaweah No. 1 Diversion (EF US K1 Div)	707 (120; 587)	184 (31; 153)	25.6	6.7
East Fork Kaweah River Downstream of the Kaweah No. 1 Diversion (EF DS K1 Div)	196 (98; 98)	37 (18.5; 18.5)	20.6	4.2
East Fork Kaweah River Upstream of Confluence with Kaweah River (EF US Confl)	177 (76; 101)	72 (31; 41)	4.9	2.1

This Page Intentionally Left Blank

FIGURES

This Page Intentionally Left Blank



Figure AQ 9-1. Aerial view of the Kaweah No. 1 Flowline Intake with key features labeled.



Figure AQ 9-2. The Kaweah No. 1 Flowline Intake, immediately upstream of the Kaweah No. 1 Diversion (top – intake trash screen; bottom left – diversion dam; bottom right – looking down on intake and slide gate gear).

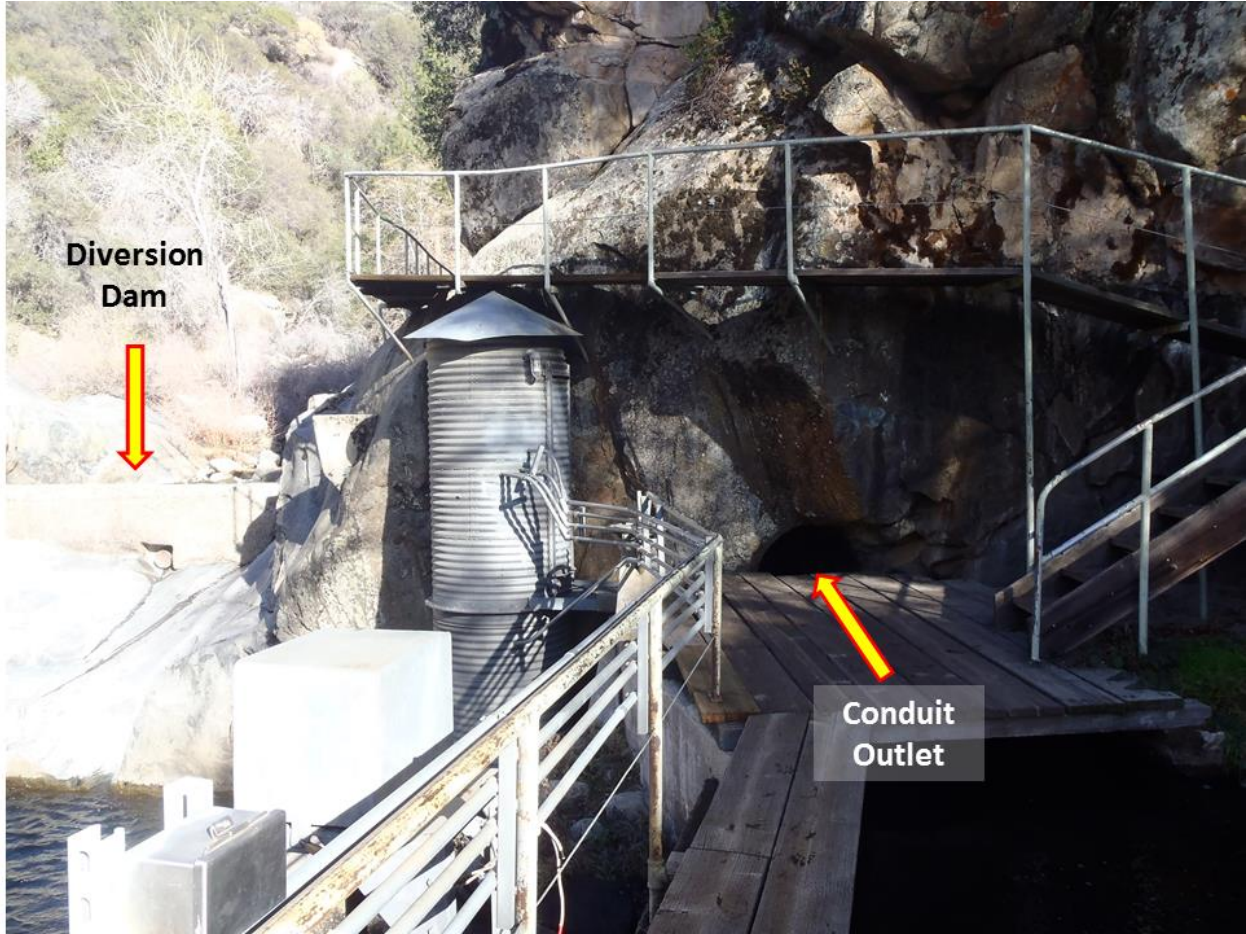

Figure AQ 9-3. A view of the Kaweah No. 1 Flowline Conduit Outlet into the sandbox.



Figure AQ 9-4. Kaweah No. 1 Flowline Fishwheel.



Figure AQ 9-5. Kaweah No. 1 Forebay Tank.



Figure AQ 9-6. Aerial view of the Kaweah No. 2 Flowline Intake with key feature labeled.



Figure AQ 9-7. The Kaweah No. 2 Flowline Intake, immediately upstream of the Kaweah No. 2 Diversion Dam. Flow is from right to left in the image.



Figure AQ 9-8. Detail, looking down on the Kaweah No. 2 Flowline Intake Grate. Flow is from right to left in the image.



Figure AQ 9-9. Kaweah No. 2 Flowline Fishwheel.



Figure AQ 9-10. Kaweah No. 2 Forebay, Flume and Penstock, and Drains.



Figure AQ 9-11. Aerial view of the Kaweah No. 3 Flowline, Forebay, Drains, and Penstock.



Figure AQ 9-12. Fyke net and live car set up at Kaweah No. 1 Flowline (left image looking upstream, right image looking downstream). Flow approximately 7.2 cfs.



Figure AQ 9-13. Drift net with 12-inch by 17-inch rectangular opening deployed in Kaweah No. 1 Flowline immediately downstream of the flowline sampling section where the flowline water was returned back to the East Fork Kaweah River. Flow approximately 6.2 cfs.



Figure AQ 9-14. Kaweah No. 2 Flowline fyke net and drift net sampling location.



Figure AQ 9-15. Fyke net with wing walls and live car set up at Kaweah No. 2 Flowline.



Figure AQ 9-16. Three drift nets with 6-inch diameter opening deployed in Kaweah No. 2 Flowline at a wooden bridge immediately upstream of the fyke trap location.



Figure AQ 9-17. Juvenile Sacramento pikeminnow caught in the fyke trap during the late spring sampling at Kaweah No. 2 Flowline.

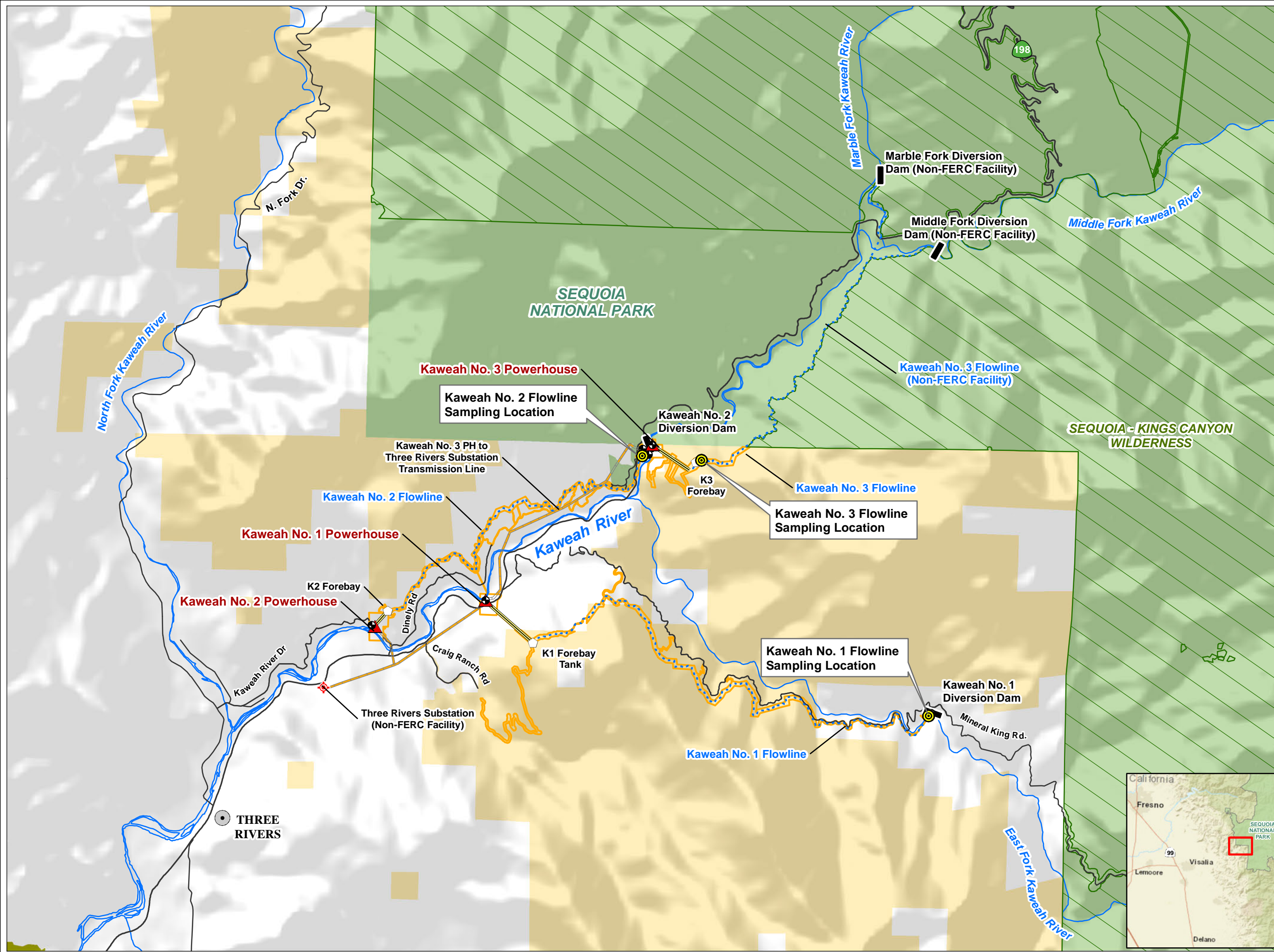

Figure AQ 9-18. Three drift nets with 6-inch diameter opening deployed at a wooden bridge immediately upstream of the Kaweah No. 3 Forebay.

This Page Intentionally Left Blank

MAPS

This Page Intentionally Left Blank



- SCE Facilities**
- Powerhouse
 - Diversion
 - Utility
 - Forebay
 - Gage
 - Flowline
 - Penstock
 - Transmission Line
 - Project FERC Boundary
- Other Features**
- Dam
 - City/Town
 - Highway/Road
 - Watercourse
 - Water Body
- Land Jurisdiction***
- Bureau of Land Management
 - U.S. Army Corps of Engineers
 - National Park Service
 - Private (Blank)
- *SOURCE: BLM 2016
- Land Management**
- National Wilderness Area
- Entrainment Study**
- Entrainment Sampling Location



SOUTHERN CALIFORNIA EDISON
An EDISON INTERNATIONAL® Company

Kaweah Project - FERC Project No. 298

Map AQ9-1

Kaweah Project
Entrainment Sampling Locations



Date: 12/5/2019

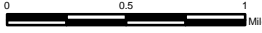

0 0.5 1 Miles

Projection: UTM Zone 11
Datum: NAD 83

Southern California Edison (SCE) has no reason to believe that there are any inaccuracies or defects with information incorporated in this work and make no representations of any kind, including, but not limited to, the warranties of merchantability or fitness for a particular use, nor are any such warranties to be implied, with respect to the information or data, furnished herein. No part of this map may be reproduced or transmitted in any form or by any means, electronic or mechanical, including photocopying and recording system, except as expressly permitted in writing by SCE.

This Page Intentionally Left Blank

APPENDIX A

Individual Sampling Period Results

This Page Intentionally Left Blank

Appendix A Table 1. Results of fyke net entrainment sampling in Kaweah flowlines in 2019.

Flowline	Sampling Date	Time Window ¹	Time Deployed (hours)	Water Volume Sampled (ft ³)	Water Volume through Flowline (ft ³)	Average Flowline Flow (cfs) ²	Number of Fish Captured	Percent of Flow Sampled	Number of Fish / Hour Captured	Estimated Number of Fish / Hour Entrained	Estimated Number of Fish / Hour / cfs Entrained
K1	May 14, 2019	8:00am–1:00pm	4.0	102960.0	102960.0	7.3	0	100	0	0	0
		3:00pm–8:00pm	4.0	104040.0	104040.0	7.3	0	100	0	0	0
		10:00pm–3:00am	0.7 ³	19507.5	19507.5	7.5	0	100	0	0	0
	Totals	-	8.7	226507.5	226507.5	7.4	0	100	0	0	0
K2	May 7, 2019	8:00am–1:00pm	4.0	511026.4	511026.4	33.3	0	100	0	0	0
		3:00pm–8:00pm	3.9	519532.1	519532.1	36.9	0	100	0	0	0
		10:00pm–3:00am	3.8	507609.0	507609.0	37.6	0	100	0	0	0
	May 8, 2019	8:00am–1:00pm	4.1	545314.9	545314.9	37.1	0	100	0	0	0
		3:00pm–8:00pm	4.0	533104.9	533104.9	37.0	0	100	0	0	0
		10:00pm–3:00am	4.0	542817.0	542817.0	37.7	0	100	0	0	0
	May 9, 2019	8:00am–1:00pm	4.0	540406.6	540406.6	37.5	0	100	0	0	0
		3:00pm–8:00pm	4.0	533833.4	533833.4	37.1	0	100	0	0	0
		10:00pm–3:00am	3.4 ⁴	475224.7	475224.7	38.7	1 ⁵	100	0.3	0.3	0.01
	Totals	-	35.1	4708869.0	4708869.0	37.0	1	100	0.03	0.03	0.001
	July 9, 2019	8:00am–1:00pm	4.0	518301.0	518301.0	35.9	0	100	0	0	0
		3:00pm–8:00pm	4.0	506363.3	506363.3	35.1	0	100	0	0	0
		10:00pm–3:00am	4.1	545491.1	545491.1	37.1	0	100	0	0	0
	July 10, 2019	8:00am–1:00pm	4.0	519924.7	519924.7	36.0	0	100	0	0	0
		3:00pm–8:00pm	4.0	507235.8	507235.8	35.3	0	100	0	0	0
		10:00pm–3:00am	4.1	549096.9	549096.9	37.3	0	100	0	0	0
	July 11, 2019	8:00am–1:00pm	4.0	522364.2	522364.2	36.2	0	100	0	0	0
		3:00pm–8:00pm	4.0	510420.7	510420.7	35.4	0	100	0	0	0
		10:00pm–3:00am	4.1	546200.1	546200.1	37.2	0	100	0	0	0
	Totals	-	36.2	4725397.8	4725397.8	36.2	0	100	0	0	0

¹ Four hours were sampled within each 5-hour time window on each day sampled.

² Average flowline flow is the average flow during the 5-hour sampling time window.

³ Sampling was cancelled early due to safety concerns.

⁴ Fyke net was removed early due to excessive debris and very turbid water in the flowline.

⁵ Fish captured was a 35 mm juvenile Sacramento pikeminnow.

Appendix A Table 2. Results of drift net entrainment sampling in Kaweah flowlines in 2019.

Flowline	Sampling Date	Time Window ¹	Time Deployed (hours)	Water Volume Sampled (ft ³)	Water Volume through Flowline (ft ³)	Average Flowline Flow (cfs) ²	Number of Fish Captured	Percent of Flow Sampled	Number of Fish / Hour Captured	Estimated Number of Fish / Hour Entrained	Estimated Number of Fish / Hour / cfs Entrained
K1	May 14, 2019	8:00am–1:00pm	4.0	33787.4	93168.0	6.6 ⁴	0	36.3	0	0	0
		3:00pm–8:00pm	4.0	34594.9	94248.0	6.6 ⁴	0	36.7	0	0	0
		10:00pm–3:00am	0.5 ³	2624.4	11616.0	6.9 ⁴	0	22.6	0	0	0
	Totals	-	8.5	71006.8	199032.0	6.7	0	35.7	0	0	0
K2	May 7, 2019	8:00am–1:00pm	4.0	140370.8	533147.3	33.3	0	26.3	0	0	0
		3:00pm–8:00pm	4.0	115229.2	529877.6	36.9	0	21.7	0	0	0
		10:00pm–3:00am	4.0	127744.4	536553.2	37.6	0	23.8	0	0	0
	May 8, 2019	8:00am–1:00pm	4.0	129804.0	540514.9	37.1	0	24.0	0	0	0
		3:00pm–8:00pm	4.0	118232.0	532233.0	37.0	0	22.2	0	0	0
		10:00pm–3:00am	4.0	128139.3	540639.0	37.7	0	23.7	0	0	0
	May 9, 2019	8:00am–1:00pm	4.1	103918.4	556027.9	37.5	0	18.7	0	0	0
		3:00pm–8:00pm	4.0	106599.9	533187.0	37.1	0	20.0	0	0	0
		10:00pm–3:00am	3.7	88190.9	519195.5	38.7	0	17.0	0	0	0
	Totals	-	35.9	1058228.8	4821375.4	37.0	0	21.9	0	0	0
	July 9, 2019	8:00am–1:00pm	4.0	121033.9	519008.4	35.9	0	23.3	0	0	0
		3:00pm–8:00pm	3.9	114938.2	496267.0	35.1	0	23.2	0	0	0
		10:00pm–3:00am	3.8	105365.8	509714.0	37.1	0	20.7	0	0	0
	July 10, 2019	8:00am–1:00pm	4.0	107681.4	519831.0	36.0	0	20.7	0	0	0
		3:00pm–8:00pm	3.7	105292.4	473754.9	35.3	0	22.2	0	0	0
		10:00pm–3:00am	3.8	108295.8	504613.7	37.3	0	21.5	0	0	0
	July 11, 2019	8:00am–1:00pm	4.0	115182.6	522810.0	36.2	0	22.0	0	0	0
		3:00pm–8:00pm	4.0	113430.1	513542.4	35.4	0	22.1	0	0	0
		10:00pm–3:00am	3.9	105200.4	517637.0	37.2	0	20.3	0	0	0
	Totals	-	35.1	996420.6	4577178.4	36.2	0	21.8	0	0	0

Flowline	Sampling Date	Time Window ¹	Time Deployed (hours)	Water Volume Sampled (ft ³)	Water Volume through Flowline (ft ³)	Average Flowline Flow (cfs) ²	Number of Fish Captured	Percent of Flow Sampled	Number of Fish / Hour Captured	Estimated Number of Fish / Hour Entrained	Estimated Number of Fish / Hour / cfs Entrained	
K3	May 21, 2019	8:00am–1:00pm	3.8	72846.5	800900.0	58.6	0	9.1	0	0	0	
		3:00pm–8:00pm	3.9	75297.6	820510.2	58.8	0	9.2	0	0	0	
		10:00pm–3:00am	3.8	81891.5	804418.1	58.7	0	10.2	0	0	0	
	May 22, 2019	8:00am–1:00pm	4.0	91387.3	825925.0	58.0	0	11.1	0	0	0	0
		3:00pm–8:00pm	4.0	86545.8	843429.1	58.4	0	10.3	0	0	0	0
		10:00pm–3:00am	3.9	91434.7	811506.0	58.7	0	11.3	0	0	0	0
	May 23, 2019	8:00am–1:00pm	4.2	96412.5	879574.2	58.2	0	11.0	0	0	0	0
		3:00pm–8:00pm	4.0	88055.9	836741.4	58.3	0	10.5	0	0	0	0
		10:00pm–3:00am	3.9	89420.3	827046.3	58.6	0	10.8	0	0	0	0
	Totals	-	35.4	773292.1	7450050.2	58.5	0	10.4	0	0	0	0
	July 23, 2019	8:00am–1:00pm	4.9	113573.3	1240465.7	89.5	0	9.2	0	0	0	0
		3:00pm–8:00pm	4.0	125481.5	1264302.1	88.0	0	9.9	0	0	0	0
		10:00pm–3:00am	3.8	100363.9	1216113.9	89.2	0	8.3	0	0	0	0
	July 24, 2019	8:00am–1:00pm	3.9	121817	1242381	88.3	0	9.8	0	0	0	0
		3:00pm–8:00pm	3.7	102182	1160893	87.2	0	8.8	0	0	0	0
		10:00pm–3:00am	3.8	102315	1252182	91.6	0	8.2	0	0	0	0
	July 25, 2019	8:00am–1:00pm	3.9	117994	1221183	86.5	0	9.7	0	0	0	0
		3:00pm–8:00pm	3.8	102244	1147291	85.9	0	8.9	0	0	0	0
		10:00pm–3:00am	3.7	96379	1195613	88.7	0	8.1	0	0	0	0
	Totals	-	35.5	982349.6	10940424.6	88.3	0.0	9.0	0	0	0	0

¹ Four hours were sampled within each 5-hour time window on each day sampled.

² Average flowline flow is the average flow during the 5-hour sampling time window.

³ Sampling was cancelled early due to safety concerns.

⁴ Flow in the tailrace channel at Kaweah No. 1 Diversion where K1 drift netting occurred equals the K1 flowline diverted flow minus 0.68 cfs being diverted down the K1 flowline to water users during sampling.

This Page Intentionally Left Blank